



Standard Fasel
Worldwide Energy Services

Welkom bij Standard Fasel



Corrosie Event - 25 Januari 2018





Standard Fasel

Worldwide Energy Services

Locaties

- Utrecht - Regio Midden
- Veendam - Regio Noord
- Barendrecht - Regio West
- Hamont - Regio Zuid





Standard Fasel

Worldwide Energy Services

Ontwerp en levering ketelinstallaties

- Cil. Stoomketels (50 ton/hr-35 bar)
- Cil. Heetwaterketels (35 MW)
- Procesketels (SGP, SRU, etc)
- Afgassen- en Waterpijpketels (150 t/hr)
- Economisers, rookgascondensors, LUVO's

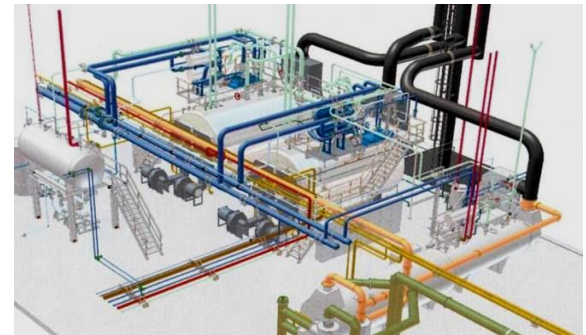



Standard Fasel

Worldwide Energy Services

Industriële branders - TAS

- Biogas/aardgas, olie, waterstof, restgassen
- Gasaanvoerdruk tot 8 bar(g)
- Groot regelbereik > 1:10
- Capaciteit 4-28 MW
- Low NOx <55 mg/Nm³

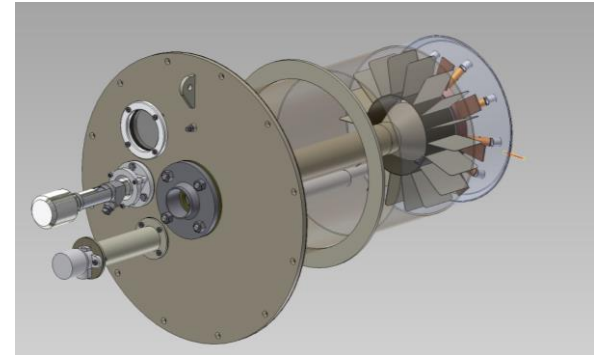



Engineering

- Haalbaarheidsstudies van wijzigingen
- Modellering met CFD simulatie
- Maatwerkoplossingen

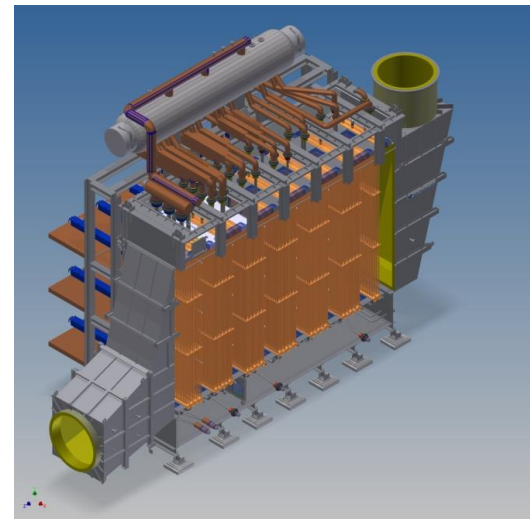



Standard Fasel

Worldwide Energy Services

Productie

- Drukdelen en warmtewisselaars
- Procesketels
- Ontgassers, condensors, LUVO's
- Hogedruk leidingwerk en staalconstructies
- Hooggelegeerd staal
- EN, TRD, RToD, ASME, AD-Merkblatter





Standard Fasel

Worldwide Energy Services

Service 24/7

- Alle types stoomketels en branders
- Ketelkeuringen en reparaties
- Branderinspecties en onderhoud
- E&I en besturingstechnologie





Standard Fasel
Worldwide Energy Services

Cilindrische ketels





Branderombouw



Low NOx – Gas + Olie
50 mg/nm³ – 100 mg/nm³





Standard Fasel
Worldwide Energy Services

Rookgascondensor





Standard Fasel

Worldwide Energy Services

Flashvat

***Warmte terugwinning
uit spuiwater of retour-
condensaat***

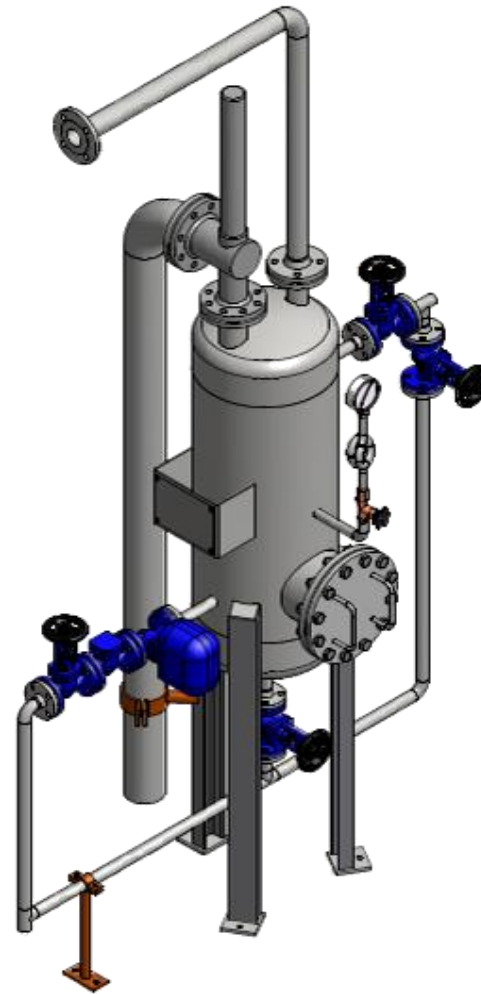



Standard Fasel
Worldwide Energy Services

Werkspoor

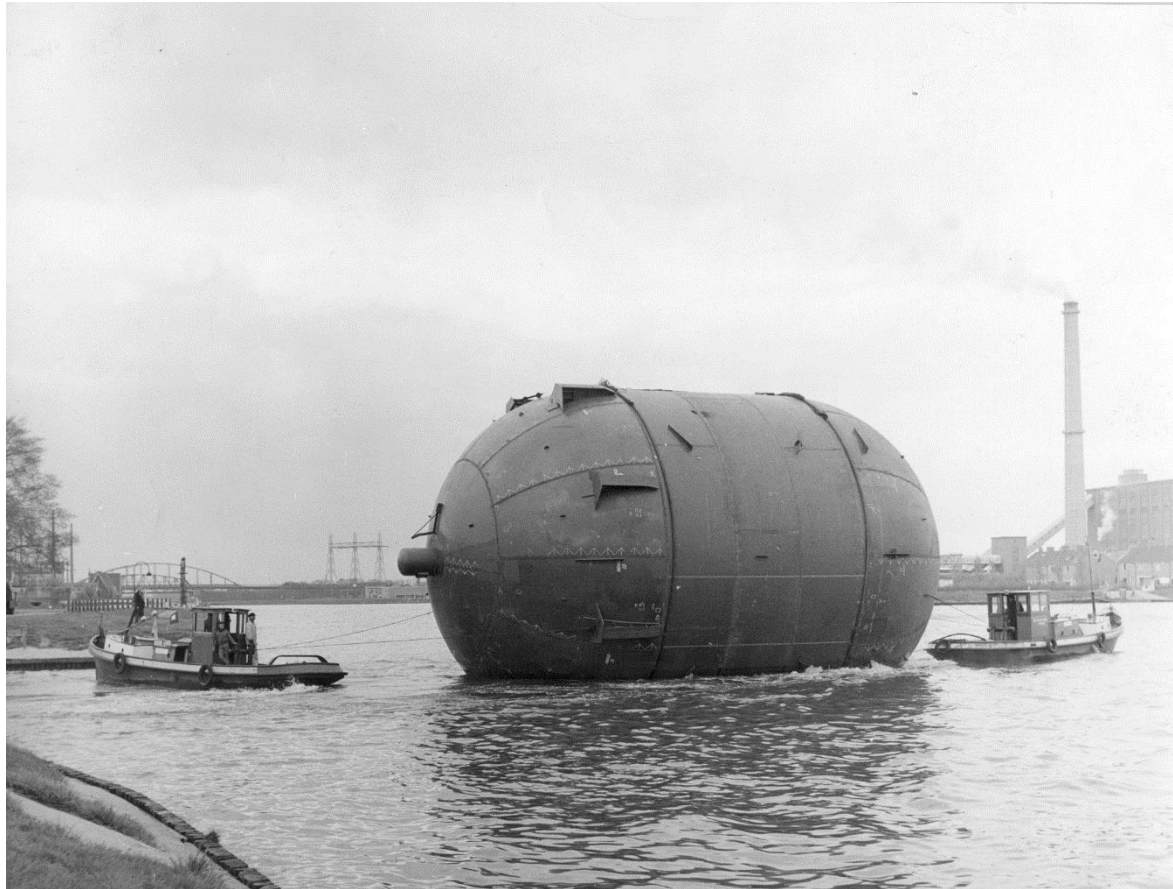



Standard Fasel
Worldwide Energy Services

Bronswerk

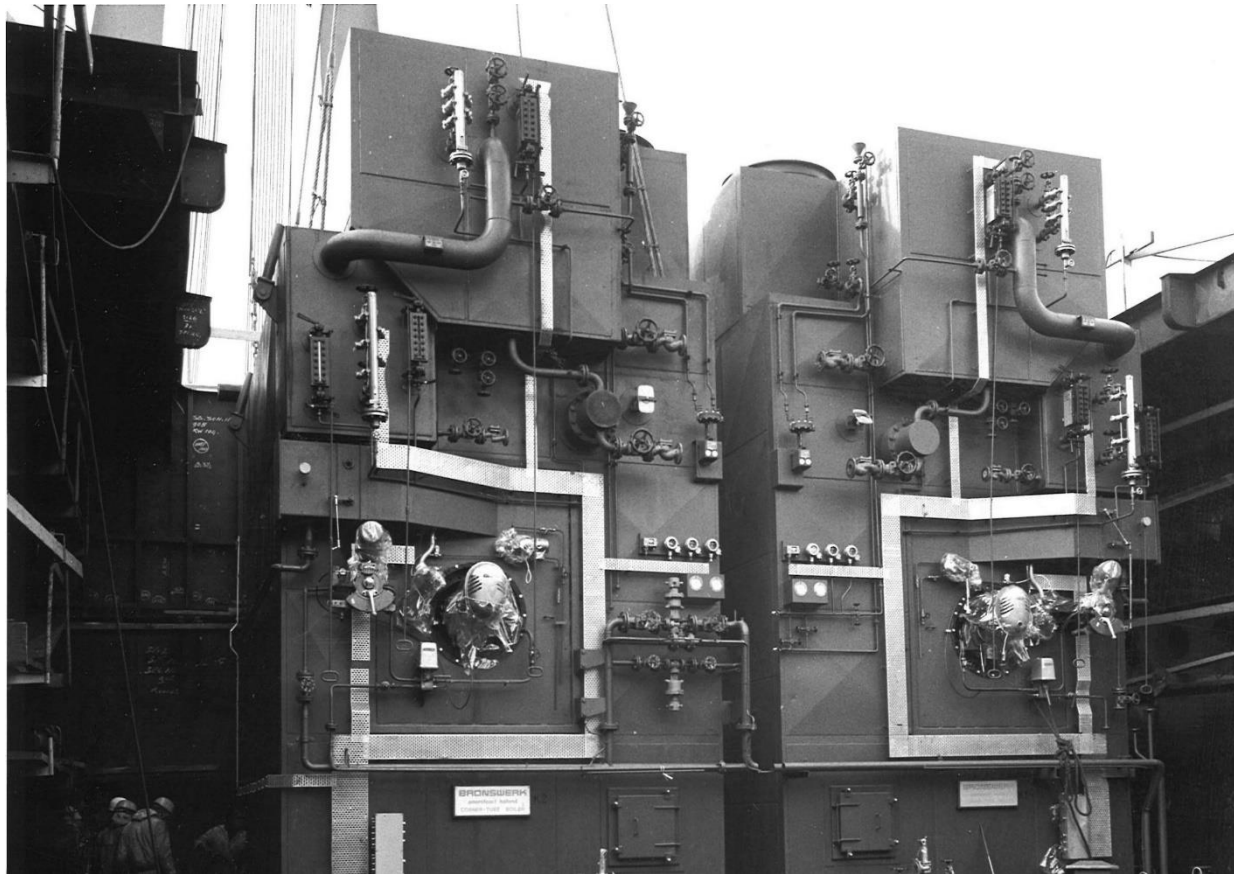



Standard Fasel
Worldwide Energy Services

Standard Fasel - Lentjes





Standard Fasel
Worldwide Energy Services

TAS branders



TAS

the company with a spark





Standard Fasel

Worldwide Energy Services

Bedankt voor uw aandacht!



Standard Fasel

Worldwide Energy Services

Daan Scheepens
Consultant

Krommewetering 13 · 3543 AP Utrecht
P.O. Box 2435 · 3500 GK Utrecht
The Netherlands

dscheepens@standardfasel.nl
www.standardfasel.nl

Phone +31 30 2449211
Direct +31 30 2449203
Mobile +31 6 100 456 26

