

Energy storage in hydrogen



Mascha Smit
KIVI symposium
Energieopslag
12 april 2017

Changing energy system

- today: linear system from producer to consumer, separated 'lines' for different carriers
- future: complex interconnected system of different energy carriers with producers, prosumers and consumers
- Hydrogen part of energy system

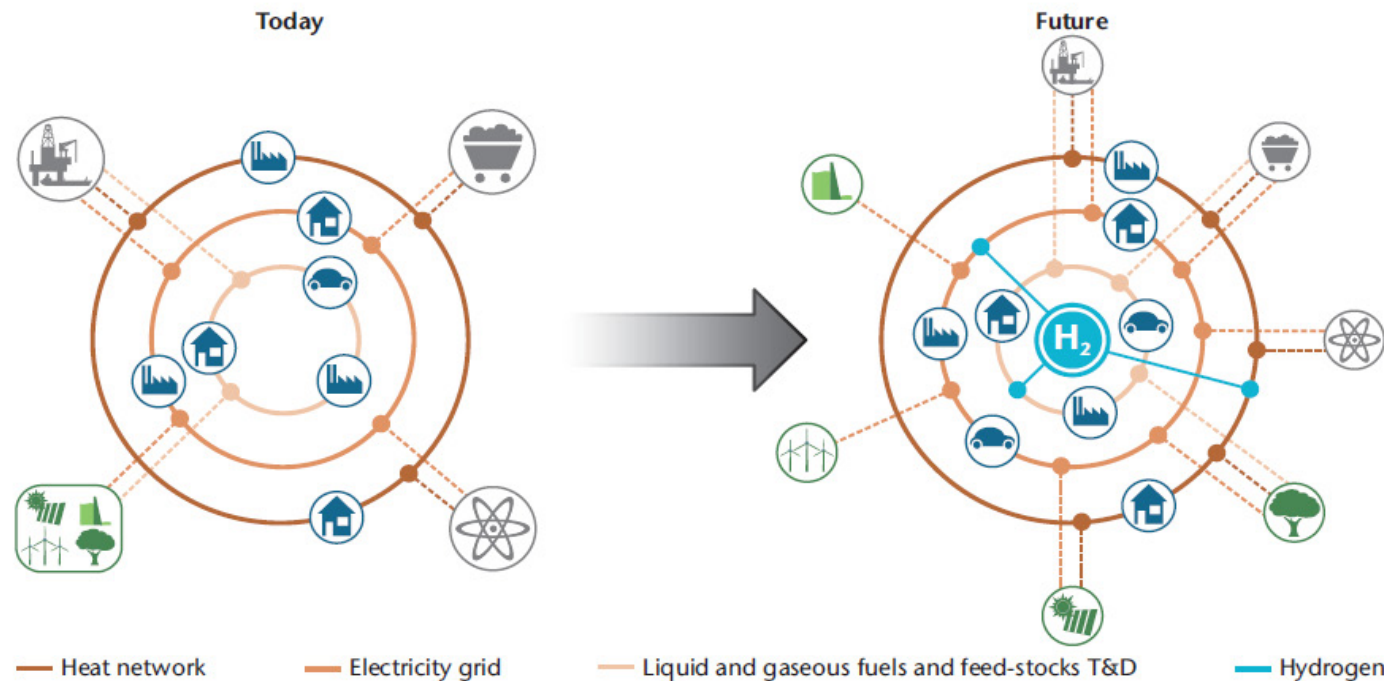

Need for seasonal energy storage

- **gasless future?**
- **electrical heating or heating network**
- **heating with heatpump will increase electricity consumption during winter ~4 times**
- **monthly RE production capacity NL more or less constant:**
 - summer: less wind
 - winter: less sun
- **electrical heating requires more windturbines and seasonal storage**

Energy storage

- only hydrogen suited for large scale seasonal storage

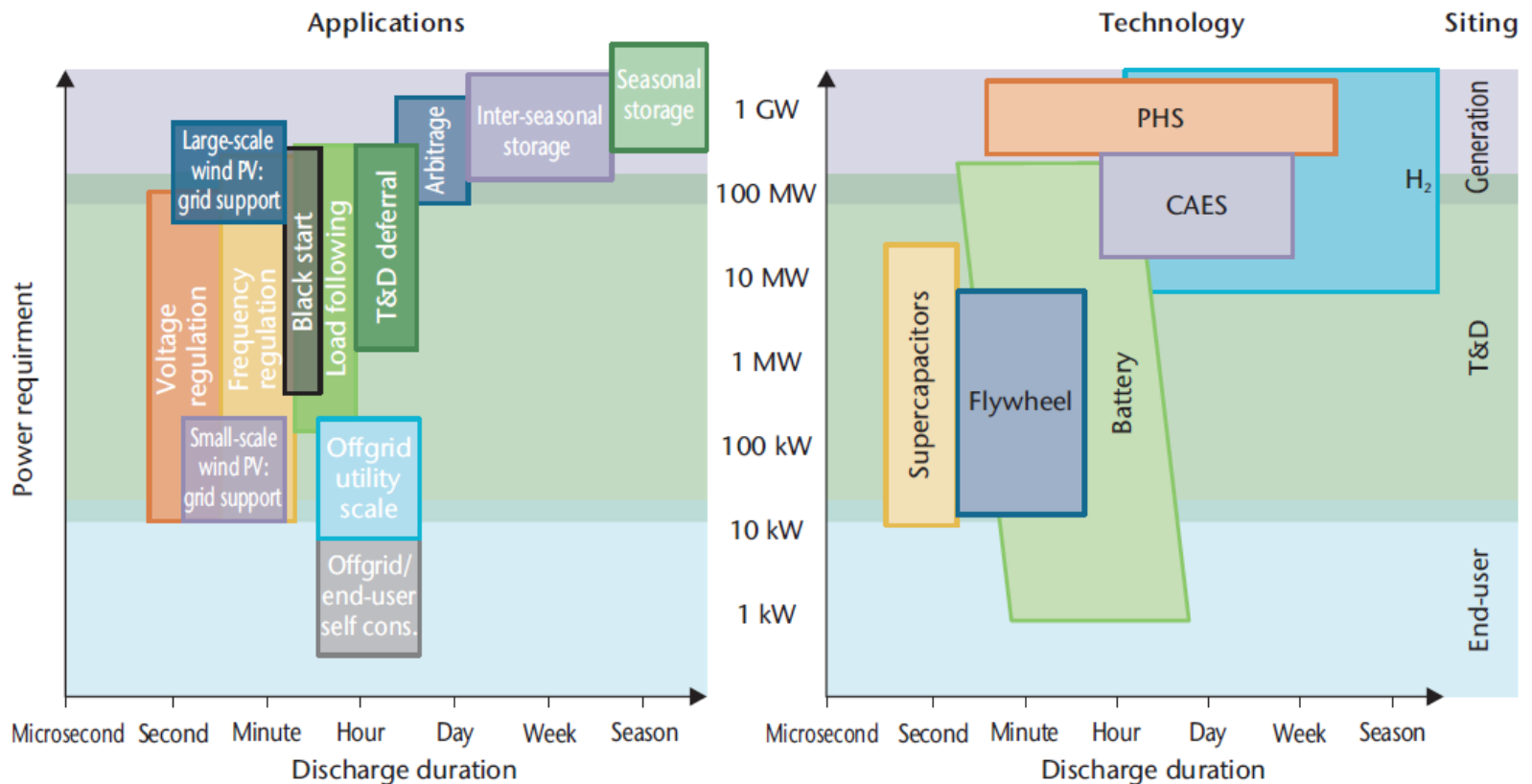

Note: CAES = compressed air energy storage; PHS = pumped hydro energy storage.



Hydrogen for energy storage

- **Use excess renewable energy**
 - offshore wind GW-scale
 - low tot negative price
 - add to energy balance!
- **Produce H₂ in large quantities**
 - cheaper due to large scale installation
 - use oilrig facilities?
 - store, ship, transport
- **Use when needed**
 - electricity
 - heating (winter only)
 - transport
 - industry

'smart grid'

- smart use of flexible energy pricing

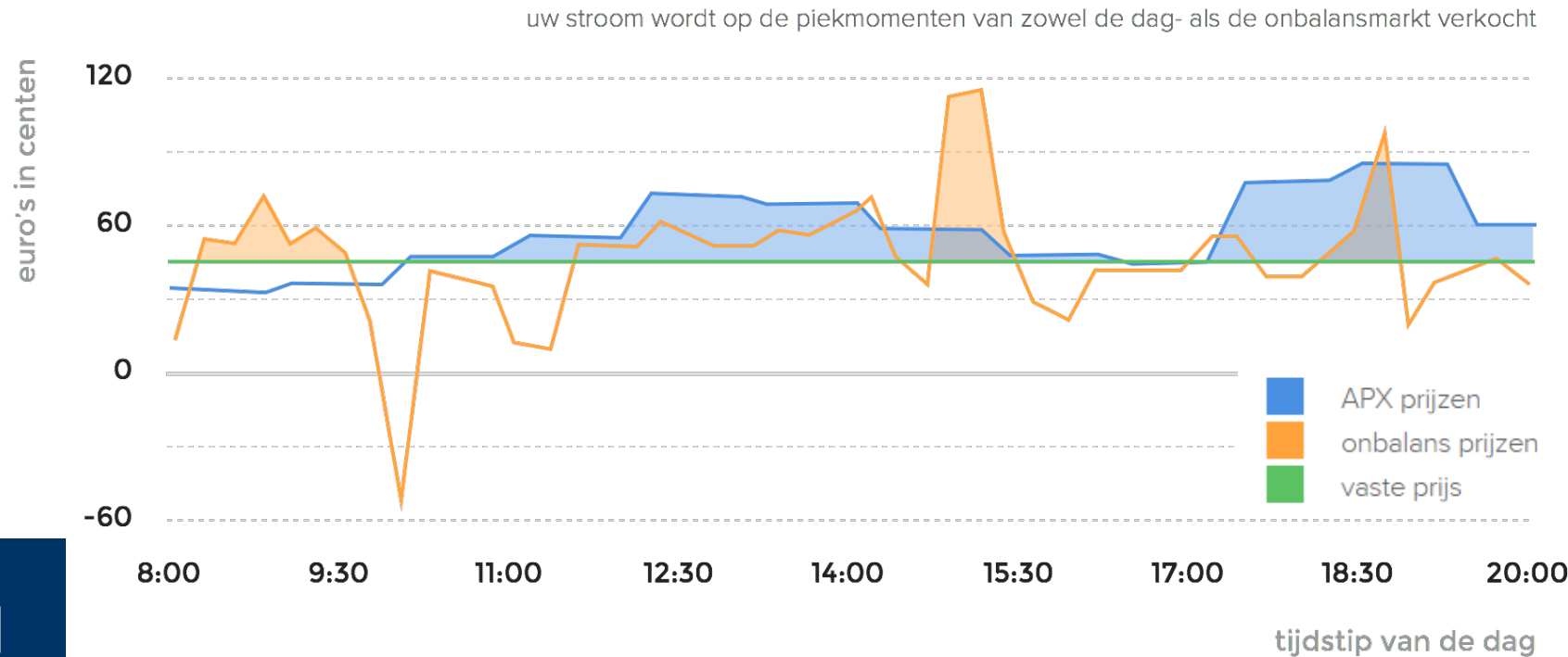

Dutch fuel vision

Dutch report 'Energieakkoord voor duurzame groei' (2013) includes targets for sustainable transport:

- 2030 max. 25 Mton CO₂ from transport (17% less than 1990)
- From 2035 on all new vehicles for personal use emission-free.
- comply with EU target 2050: 60% less CO₂ than 1990

Four simultaneous routes for transport in report 'Brandstofvisie' (2013) en Agenda (2015):

- Electric vehicles
- Hydrogen technology
- Renewable gas
- Increased efficiency

Emission scenario transport

- FCEV's will lead to reduces GHG emissions

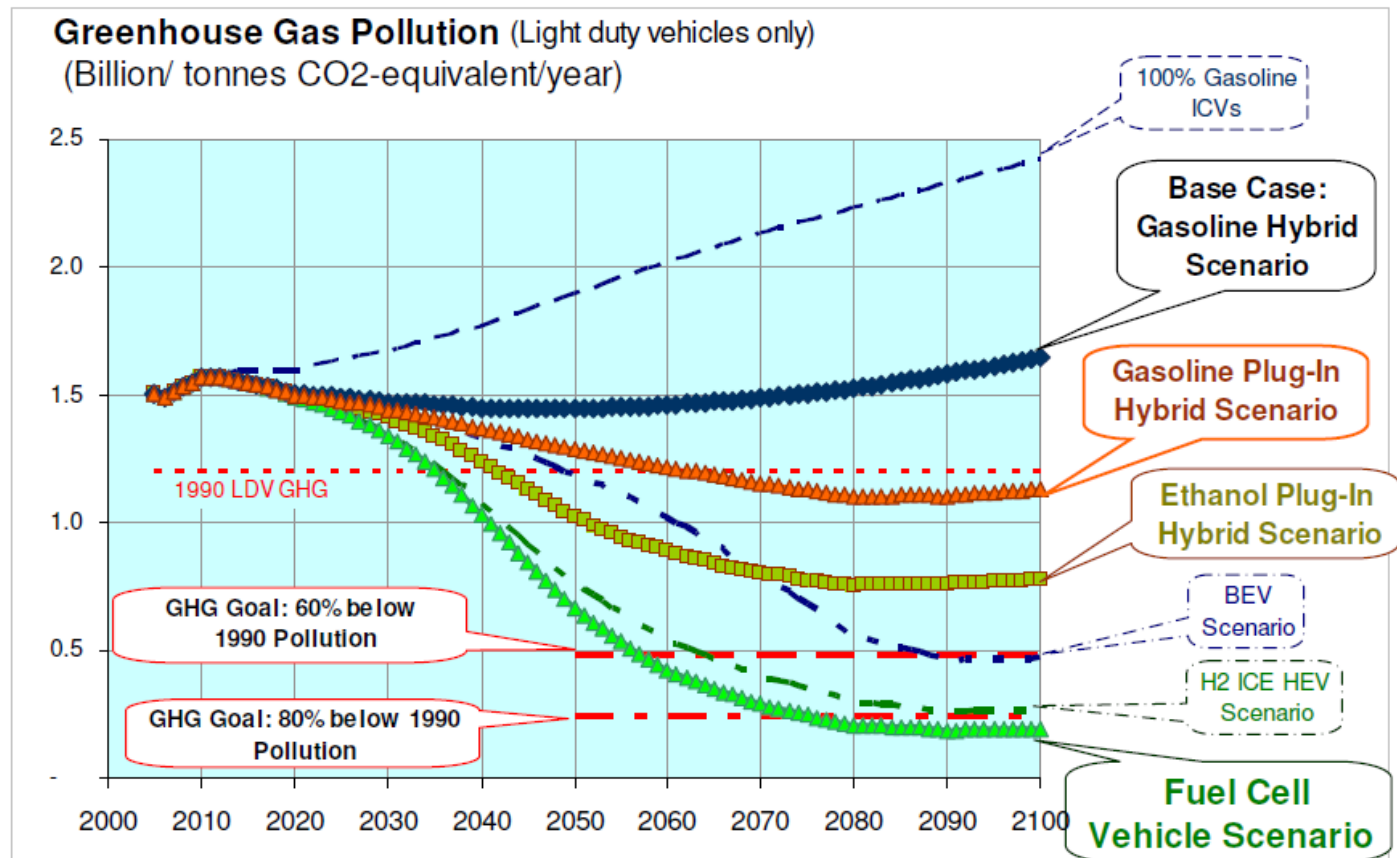

Why hydrogen?

- **energy carrier**
- **NO emissions!**
 - from renewable sources
- **availability**
 - H₂ production locally or centralized from multiple sources
- **non-toxic, non-carcinogenic**
- **high efficiency**
 - electrical: ~50%
 - cogen: >90%
- **can be 100% renewable**

Hydrogen technology requires....

- **H₂ production**
- **H₂ storage**
- **H₂ transport & distribution**
- **conversion of H₂ to energy**
 - fuel cells
 - electricity and heat
- **suitable applications**
- **laws, standards, education, etc.**

H2 Production

- **Steam Methane Reforming**
 - natural gas
- **Alkaline electrolyzer**
- **PEM electrolyzer**
- **bio-processes**
- **others**

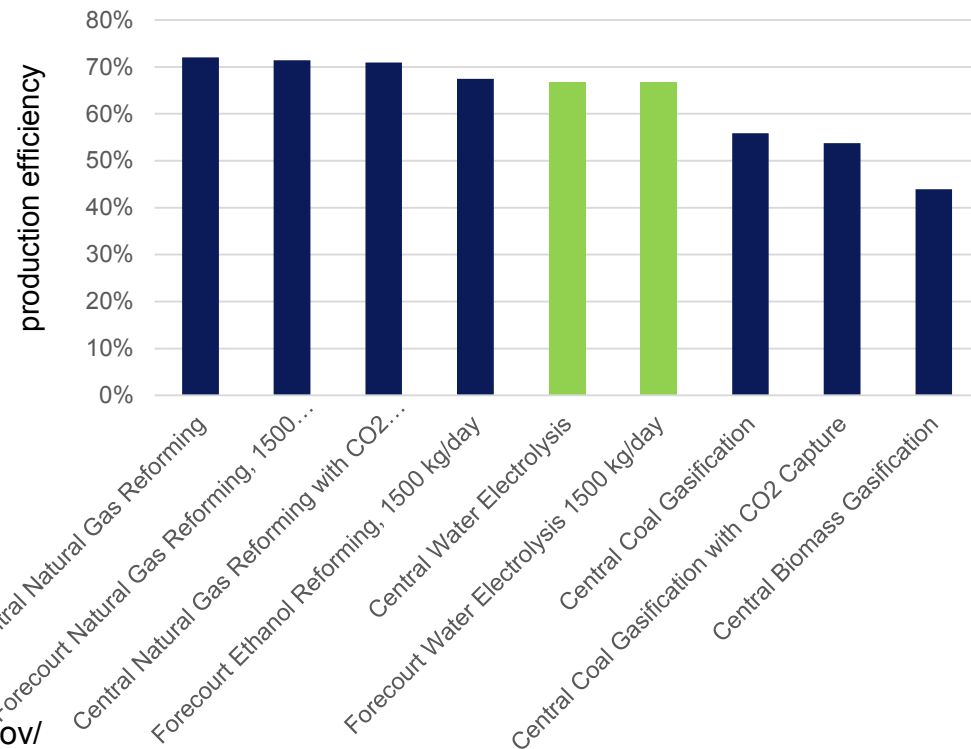

Storage & transport

- small and light = specialized techniques and materials
- compressed
- cryogenic
- in solids
- underground?
- convert to other carrier?
 - methanation
- pipelines (nat. gas network)
- ships/trailers

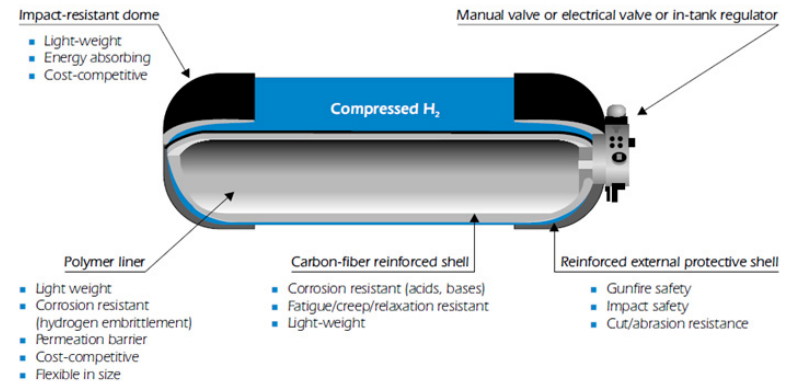

Conversion to electricity in fuel cell

- different fuel cell types for different applications



How a fuel cell makes electricity
(polymer electrolyte fuel cell)

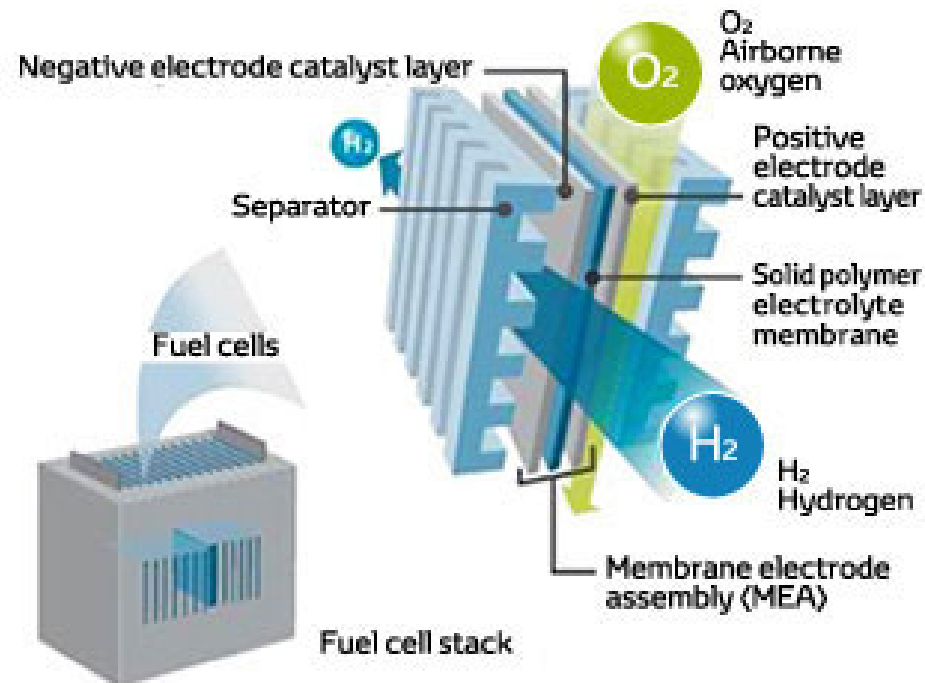
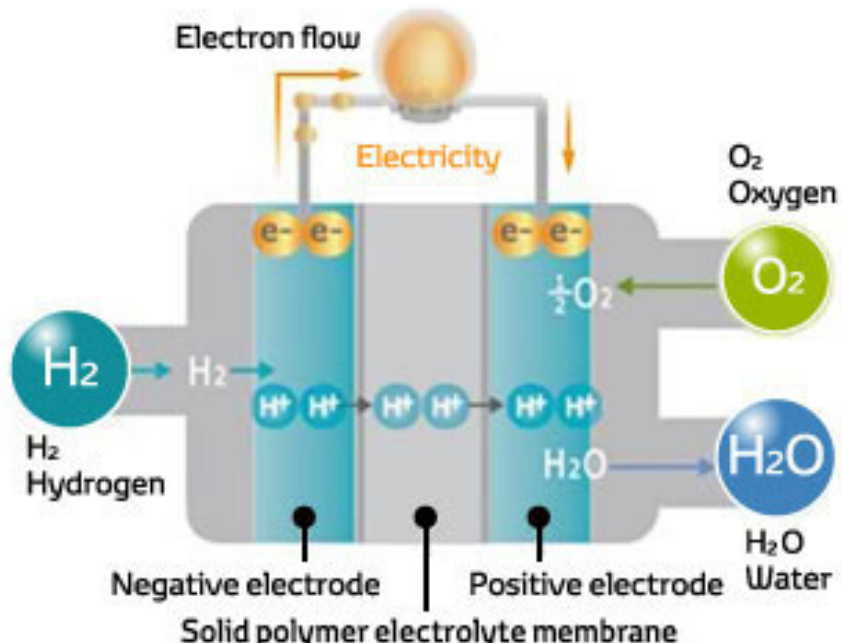

Current status and cost of H2 technology

<i>Application</i>	<i>Power or capacity</i>	<i>Efficiency *</i>	<i>Initial investment cost</i>	<i>Life time</i>	<i>Maturity</i>
Alkaline FC	Up to 250 kW	~50% (HHV)	USD 200-700/kW	5 000-8 000 hours	Early market
PEMFC stationary	0.5-400 kW	32%-49% (HHV)	USD 3 000-4 000/kW	~60 000 hours	Early market
PEMFC mobile	80-100 kW	Up to 60% (HHV)	USD ~500/kW	<5 000 hours	Early market
SOFC	Up to 200 kW	50%-70% (HHV)	USD 3 000-4 000/kW	Up to 90 000 hours	Demonstration
PAFC	Up to 11 MW	30%-40% (HHV)	USD 4 000-5 000/kW	30 000-60 000 hours	Mature
MCFC	KW to several MW	More than 60% (HHV)	USD 4 000-6 000/kW	20 000-30 000 hours	Early market
Compressor, 18 MPa	-	88%-95%	USD ~70 /kWh ₂	20 years	Mature
Compressor, 70 MPa	-	80%-91%	USD 200-400/kWh ₂	20 years	Early market
Liquefier	15-80 MW	~70%	USD 900-2 000/kW	30 years	Mature
FCEV on-board storage tank, 70 MPa	5 to 6 kg H ₂	Almost 100% (without compression)	USD 33-17/kWh (10 000 and 500 000 units produced per year)	15 years	Early market
Pressurised tank	0.1-10 MWh	Almost 100% (without compression)	USD 6 000-10 000/MWh	20 years	Mature
Liquid storage	0.1-100 GWh	Boil-off stream: 0.3% loss per day	USD 800-10 000/MWh	20 years	Mature
Pipeline	-	95%, incl. compression	Rural: USD 300 000-1.2 million/km Urban: USD 700 000-1.5 million /km (dependent on diameter)	40 years	Mature

Performance of systems for large scale H₂ storage

<i>Application</i>	<i>Power or energy capacity</i>	<i>Energy efficiency*</i>	<i>Investment cost**</i>	<i>Lifetime</i>	<i>Maturity</i>
Power-to-power (including underground storage)	GWh to TWh	29% (HHV, with alkaline EL) - 33% (HHV, with PEM EL)	1 900 (with alkaline EL) - 6 300 USD/kW (with PEM EL) plus ~8 USD/kWh for storage	20 000 to 60 000 hours (stack lifetime electrolyser)	Demonstration
Underground storage	GWh to TWh	90-95%, incl. compression	~8 USD/kWh	30 years	Demonstration
Power-to-gas (hydrogen-enriched natural gas, HENG)	GWh to TWh	~73% excl. gas turbine (HHV) ~26% incl. gas turbine (PtP)	1 500 (with alkaline EL) - 3 000 USD/kW (with PEM EL), excl. gas turbine 2 400 (with alkaline EL) - 4 000 USD/kW (with PEM EL), incl. gas turbine (PtP)	20 000 to 60 000 hours (stack lifetime electrolyser)	Demonstration
Power-to-gas (methanation)	GWh to TWh	~58% excl. gas turbine (HHV) ~21% incl. gas turbine (PtP)	2 600 (with alkaline EL) - 4 100 USD/kW (with PEM EL), excl. gas turbine 3 500 (with alkaline EL) - 5 000 USD/kW (with PEM EL), incl. gas turbine (PtP)	20 000 to 60 000 hours (stack lifetime electrolyser)	Demonstration

Conversion efficiency of H2 bases RE pathways

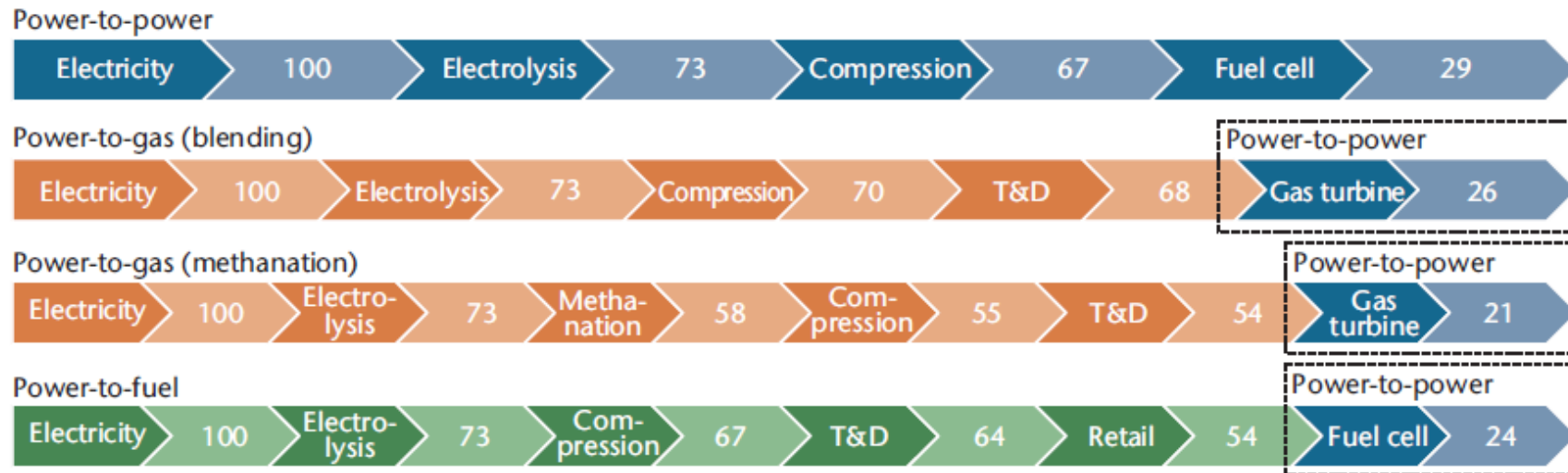

Note: The numbers denote useful energy; except for gas turbines, efficiencies are based on HHV; the conversion efficiency of gas turbines is based on LHV.



Large scale storage: H₂ system vs Tesla Powerpack

	H ₂ system 1: <i>electrolyzer, storage, fuel cell system</i>	H ₂ system 2: <i>electrolyzer, storage, fuel cell system</i>	Tesla Powerpack <i>(only short time storage)</i>
conditions	free electricity, 6 hr/day	electricity 0.06 €/kWh 12 hr/day	free electricity when needed
size (MW)	20	20	20
capacity (hr/day)	4	4	4
investment (MEuro)*	77	59	32
maintenance, replacement and operation (MEuro/yr)*	1,9	1,3	2.7
COE 20yr (Euro/kWh)	0.20	0.36	0.20

Simulation residential storage system

Part of RVO project 'energy system integration studies'

Energy-autarchic home with RE en H2-FC storage in NL

Energy from wind (10kW turbines) and PV.

Climate from KNMI (2013).

Electrolyzer, compressor, PEM fuel cell and storage tank.

FCEV or EV (100km/day) or none.

Electric load as for 5p home plus induction cooking.

With/without electrical heating (heatpump).

Warm water from FC (plus solar thermal installation
not included in model).

With/without batteries.

Current costs.

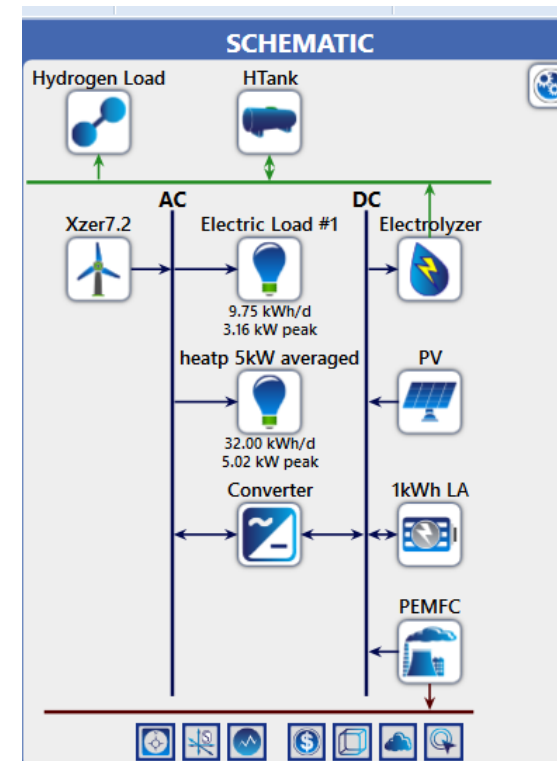

Cost RE home with H2 storage

- el. heating requires large hydrogen system for seasonal storage
 - hydrogen car requires larger electrolyzer
 - larger system equals lower price
 - cost including RE
- > cost of small scale H₂ storage today > 1 €/kWh >> electricity price

Case	FCEV	EV	Heatpump	System/component size	COE (% of lowest)
1	0	0	0	1	166
2	0	X	0	2	107
3	X	0	0	3	312
4	0	0	X	4	105
5	0	X	X	5	100
6	X	0	X	6	146

Cost example: Enefarm Japan

- **120.000 systems for residential microCHP installed**
 - heating and electricity
 - mainly from methane not H₂
- **large cost reduction due to increased production**

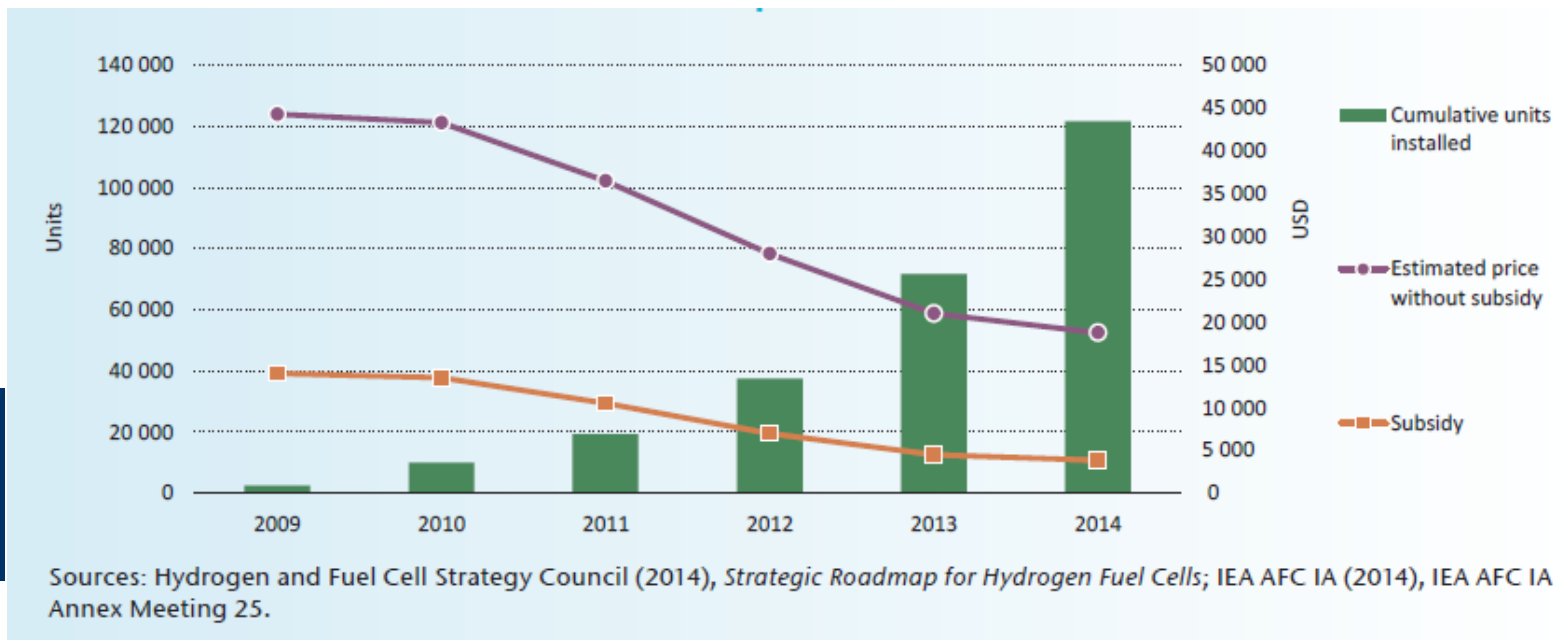

Increasing installed capacity

- stationary power plants US

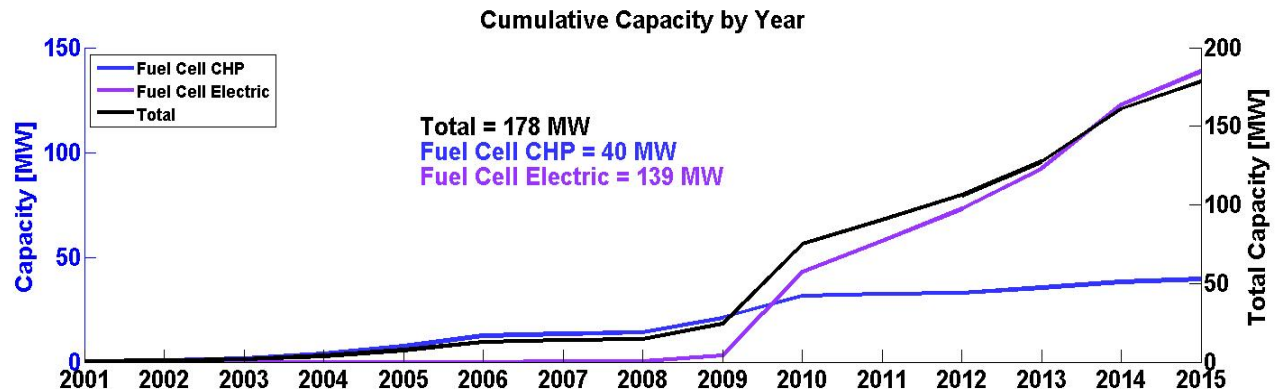
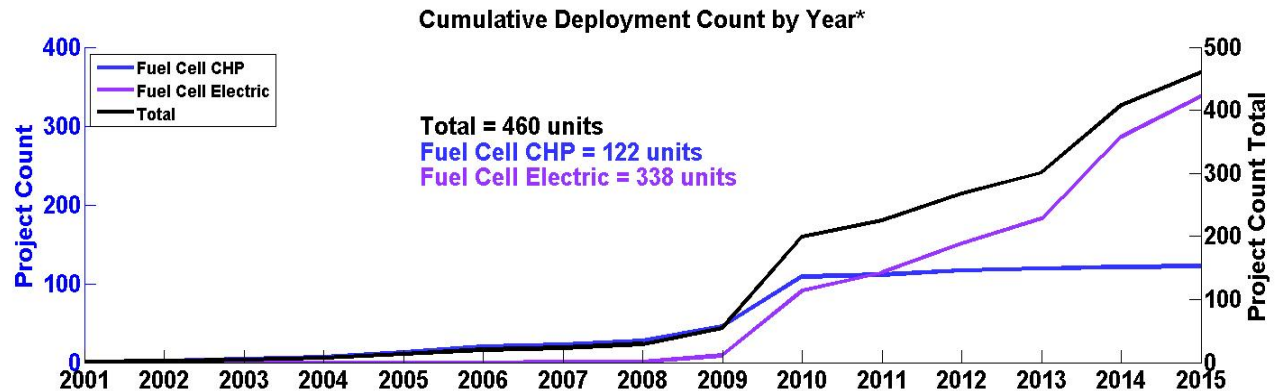

Current FC's in transport

30-9-2016: USA	30-9-2016: rest of world
<p>1,015 active vehicles</p> <ul style="list-style-type: none"> • 983 passenger vehicles - including: <ul style="list-style-type: none"> • 714 Toyota Mirai • 126 Hyundai ix35 Tucson FCEV • 47 Mercedes-Benz B-Class F-Cell • 62 Toyota Highlander FCHV-adv • 17 Honda FCX Clarity • 27 buses • 4 shuttle buses • 1 dump truck <p>+ 76 planned vehicles</p>	<p>1212 active vehicles</p> <ul style="list-style-type: none"> • 896 passenger vehicles - including: <ul style="list-style-type: none"> • 406 Toyota Mirai • 318 Hyundai ix35 Tucson FCEV • 100 Mercedes-Benz B-Class F-Cell • 5 Toyota Highlander FCHV-adv • 3 Honda FCX Clarity • 87 buses and shuttle buses • 101 scooters • 36 light commercial vehicles <p>+ 856 planned</p>



Toyota Mirai

500 km range
 3 min refuel
 5 kg H₂ @ 700 bar
 + battery = hybrid!

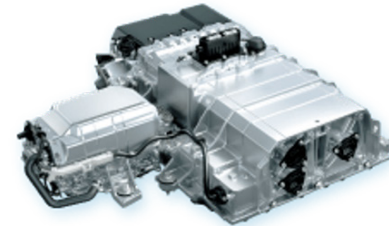

A FUTURE WITH HYDROGEN MADE POSSIBLE BY HYBRID

With decades of hybrid technology expertise behind us, we've built the perfect platform with which to develop proprietary technologies, such as the fuel cell stack. We know we can't start an alternative fuel revolution on our own though, so we've made over 5,000 fuel cell patents available for other carmakers and industries to use, royalty-free.

PCU
 The Power Control Unit has two roles: managing the power from the fuel cell stack and the battery, and readying its supply to the motor.

BATTERY
 The Mirai's nickel-metal hydride battery stores the energy that is recovered while decelerating, and also assists the fuel cell stack when you need more power during acceleration.

TANKS
 Two high-pressure carbon fibre tanks store the hydrogen as fuel. These lightweight tanks feature a world-leading power density and are capable of withstanding incredibly high forces.

FC STACK
 The Toyota fuel cell stack features a compact size and a world-leading power output for responsive performance.

VENT
 Intake grilles at the front of the vehicle deliver the car's vital ingredient, air, to the Mirai's fuel cell stack.

TOYOTA

Showroom

Innovation

Events

Sustainability

Company

News

Investors



トヨタ企業サイト



Select Region



Fuel cell vehicles are leading innovation
in two key areas.

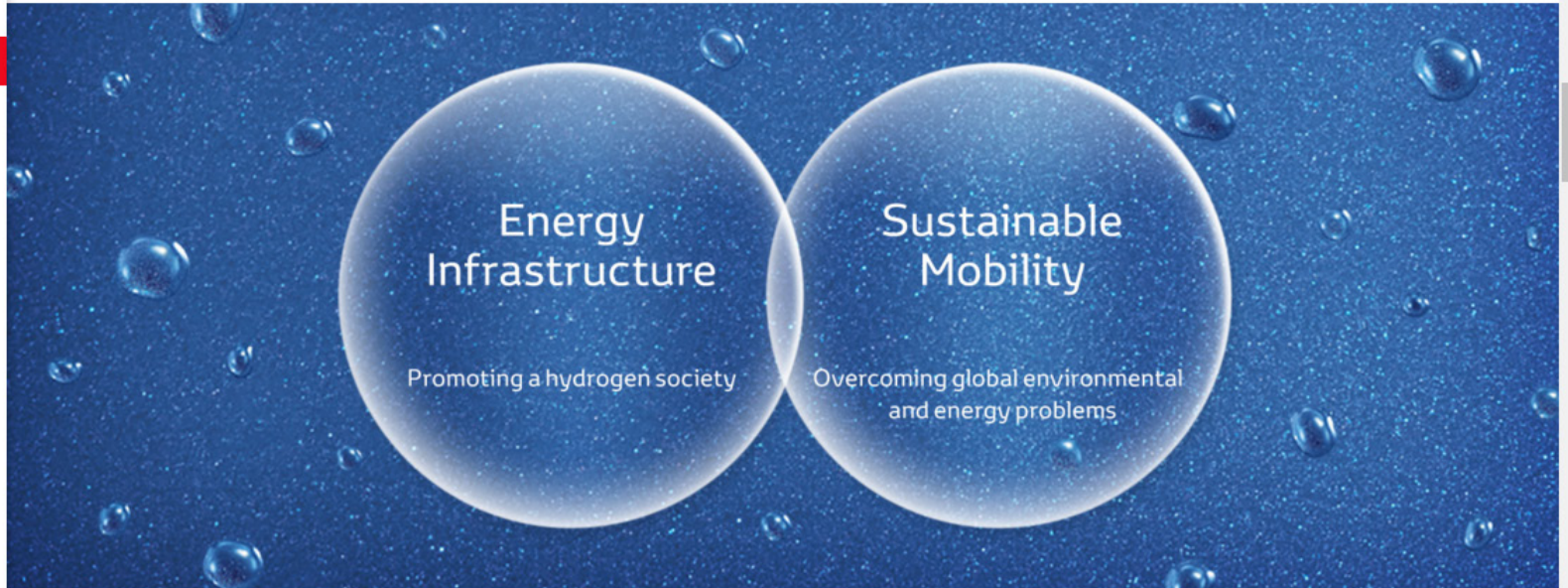

Depending on how we embrace fuel cell vehicles and hydrogen as an energy source,
the potential results could change the world and bring about innovations that far exceed even those of the Prius.

Toyota sees great potential in hydrogen
and fuel cell vehicles.



Hydrogen is a high-potential
future energy source.

H2 fueling stations - planned

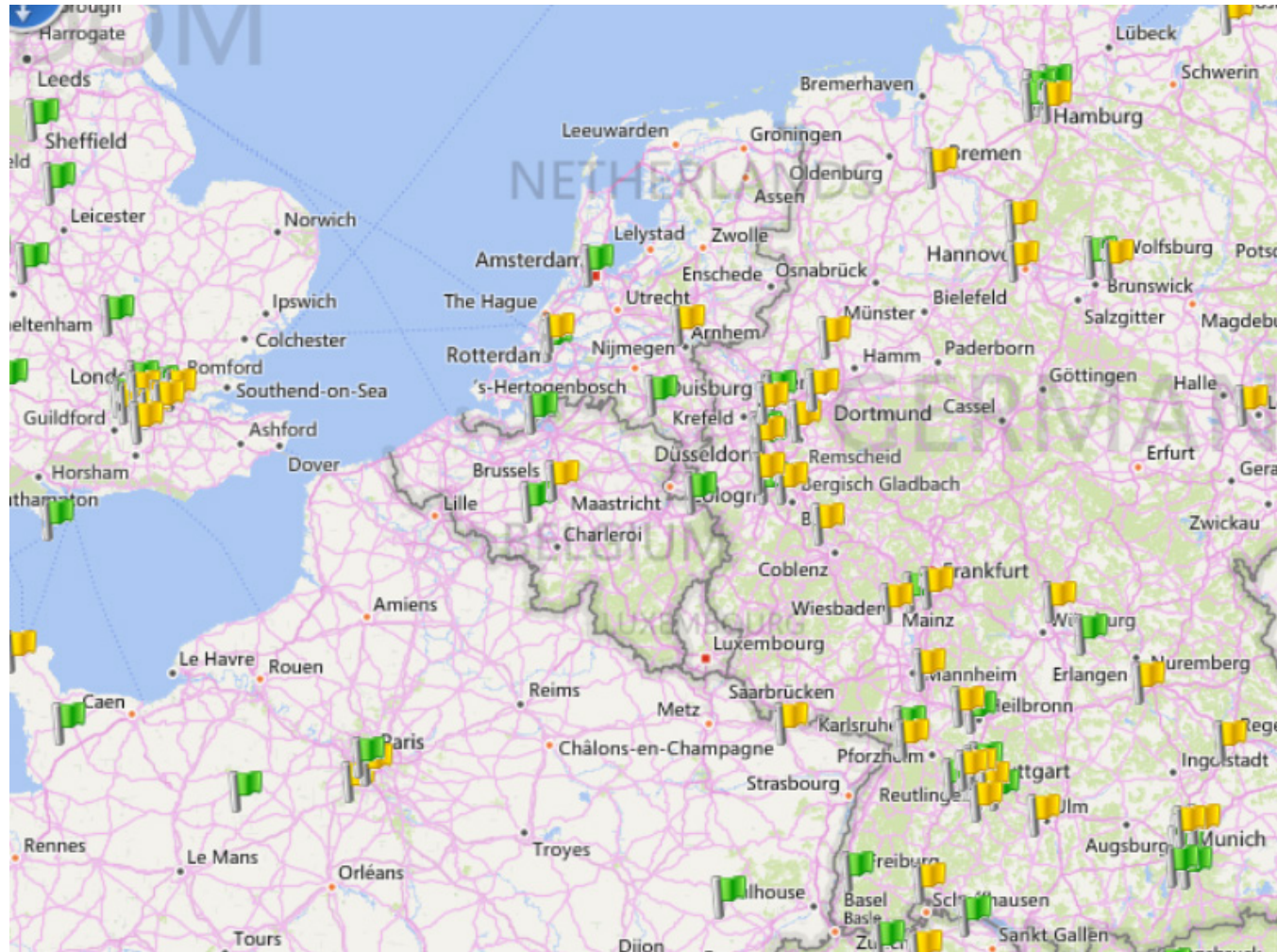

Hydrogen production capacities

- **Most hydrogen now produced from fossil fuels**
 - steam reforming or partial oxidation of methane
 - coal gasification
- **For oil refining (50%), ammonia and methanol production**
- **H₂ production capacity (Netherlands):**
 - 659 million kg/yr
 - average 20,000 km/yr/car and 8,3 million vehicles
 - enough fuel for 3,3 million vehicles
- **If all current H₂ available then 40% of required km's!**
- **Means knowledge on handling and safety no problem**

Safety

- **it is a FUEL!**
 - requires proper handling
 - like any other fuel
- **odorless, colourless**
 - requires sensors/detection
- **ignition energy varies**
 - high <10%
 - very low at 29% stoich mix

	Hydrogen	Gasoline Vapor	Natural Gas
Flammability Limits (in air)	4-74%	1.4-7.6%	5.3-15%
Explosion Limits (in air)	18.3-59.0%	1.1-3.3%	5.7-14%
Ignition Energy (mJ)	0.02	0.20	0.29
Flame Temp. in air (°C)	2045	2197	1875
Stoichiometric Mixture (most easily ignited in air)	29%	2%	9%

- **lighter than air, rapid upwards diffusion**
 - ventilated space
- **combustion only at concentrations >> than gasoline**
- **flames have low radiant heat**





Part of circular economy?

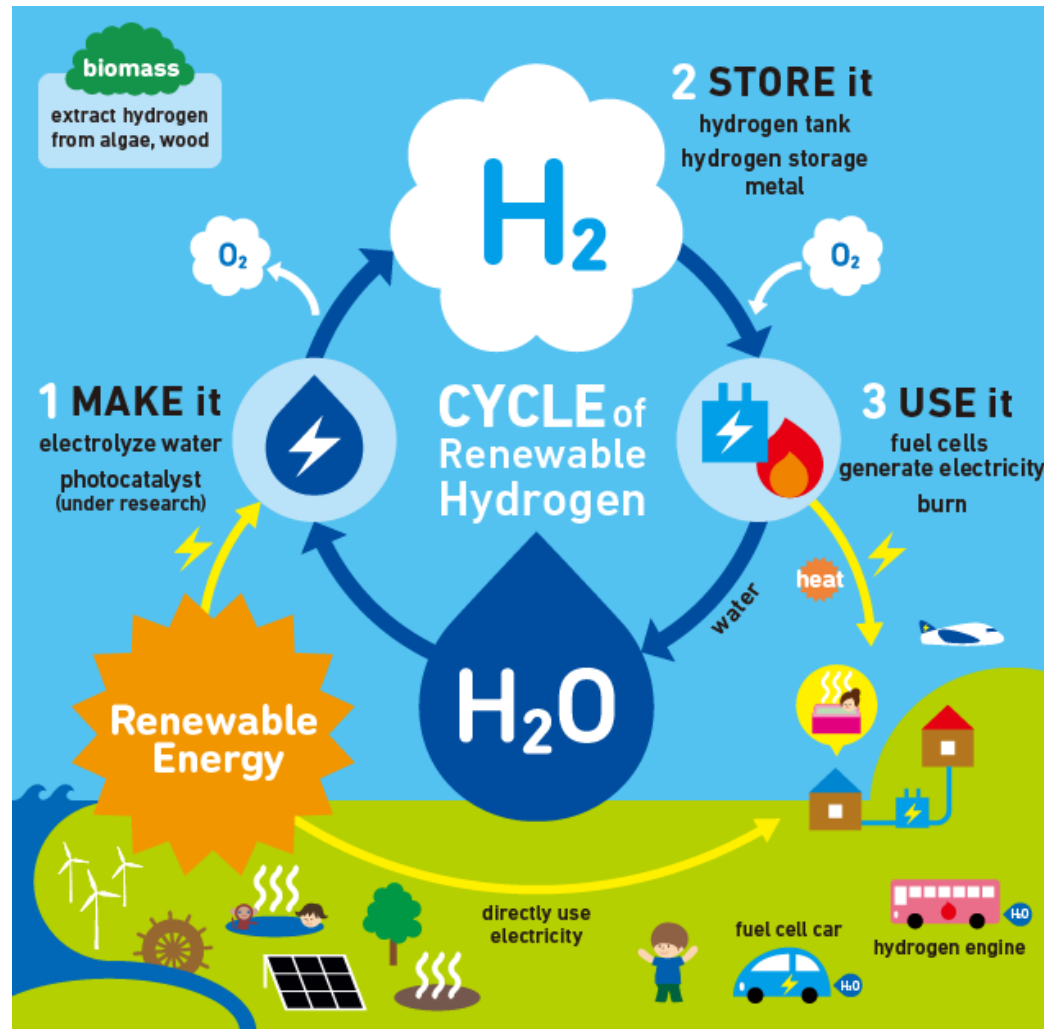

RENEWABLE ENERGY SOURCES

van Arnhem en Nijmegen

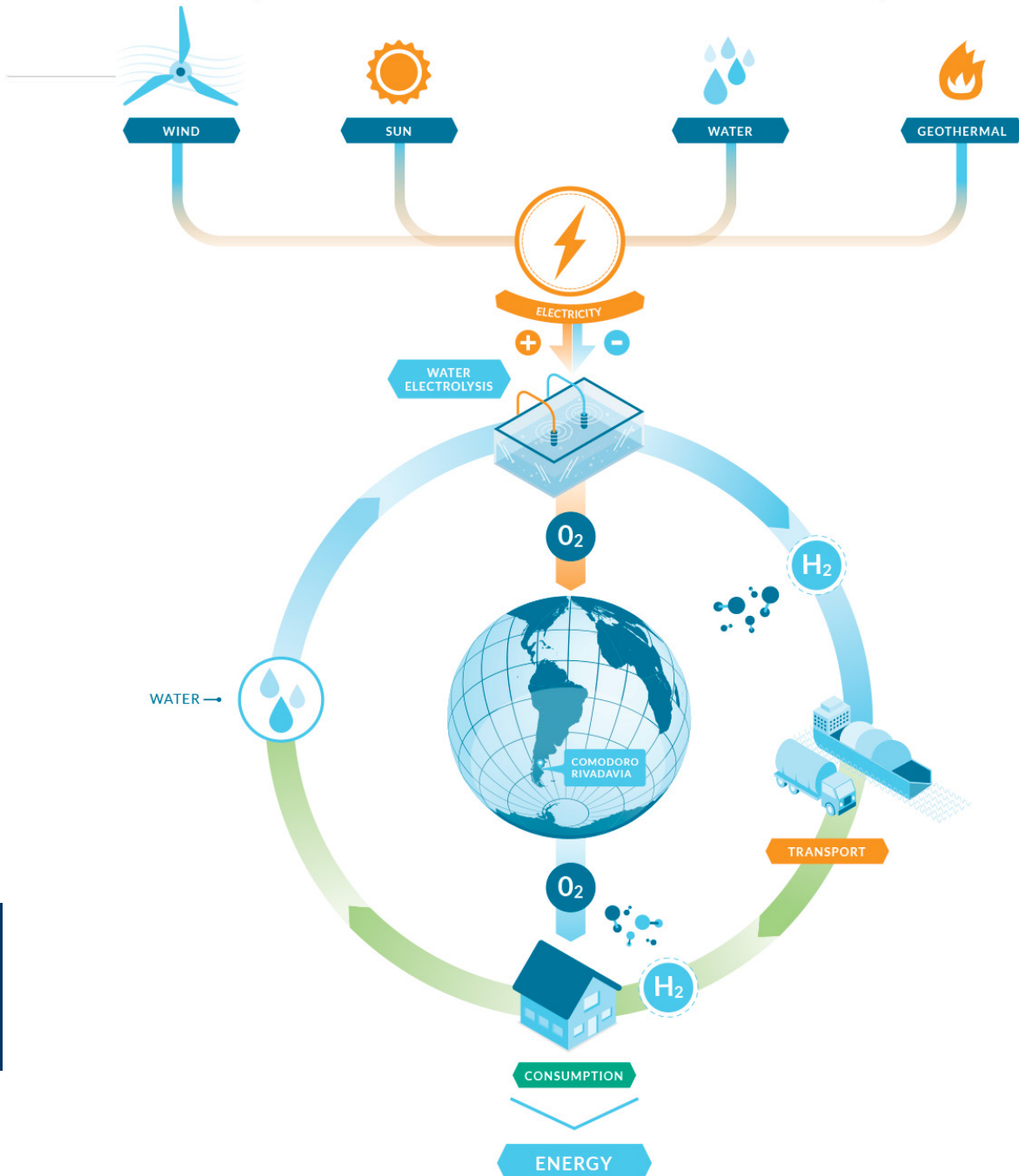

<http://www.hychico.com/assets/img/renewable-energy-sources.png>

voorbeeld diensten ipv producten FC's

- Bloom Energy
- 200kW HT fuel cell units (SOFC)

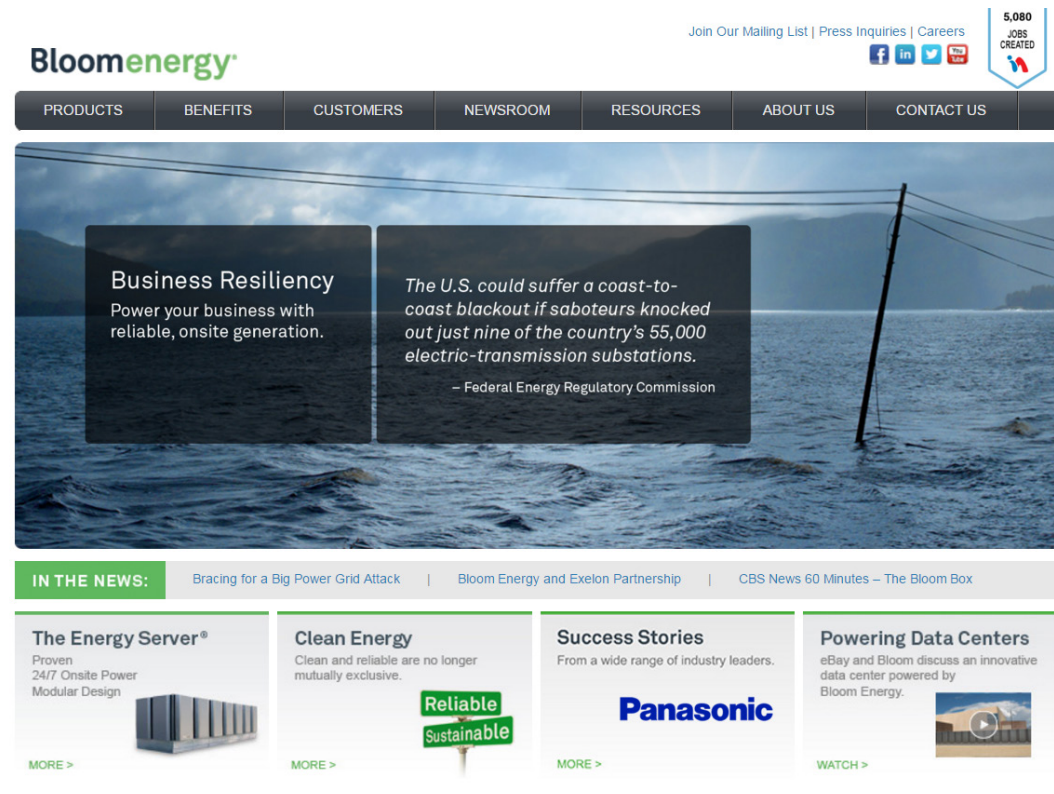

The screenshot shows the Bloom Energy website homepage. At the top right, there is a navigation bar with links for "Join Our Mailing List", "Press Inquiries", and "Careers", along with social media icons for Facebook, LinkedIn, Twitter, and YouTube. A badge on the far right indicates "5,080 JOBS CREATED". Below this is a dark navigation menu with categories: PRODUCTS, BENEFITS, CUSTOMERS, NEWSROOM, RESOURCES, ABOUT US, and CONTACT US. The main content area features a large banner image of a coastal landscape with a utility pole in the water. Two text boxes are overlaid on the banner: one on the left titled "Business Resiliency" with the text "Power your business with reliable, onsite generation.", and one on the right containing a quote: "The U.S. could suffer a coast-to-coast blackout if saboteurs knocked out just nine of the country's 55,000 electric-transmission substations." attributed to the "Federal Energy Regulatory Commission". Below the banner is a "IN THE NEWS:" section with three items: "Bracing for a Big Power Grid Attack", "Bloom Energy and Exelon Partnership", and "CBS News 60 Minutes – The Bloom Box". At the bottom, there are four content blocks: "The Energy Server®" (Proven 24/7 Onsite Power Modular Design), "Clean Energy" (Clean and reliable are no longer mutually exclusive.), "Success Stories" (From a wide range of industry leaders. featuring a Panasonic logo), and "Powering Data Centers" (eBay and Bloom discuss an innovative data center powered by Bloom Energy. featuring a video player).



klanten: <http://www.bloomenergy.com/customer-fuel-cell/>

circular economy – services?

- **sell service, not product!**
- **Bloom energy sells kWh's not fuel cells**
- **data centers etc.**

Bloom Energy Purchase and Financing Options

Bloom Energy offers customers multiple purchase and financing options to best meet their business objectives. Bloom Energy has partnered with banks, utilities and other institutional investors to offer tailored financing options to customers.

Capital Purchase

Customers who want to maximize their return on investment can purchase and install [Bloom Energy Servers](#) at their facilities and capture all of the economic benefits of producing their own power for significantly less than the price of electricity purchased from the grid.

Bloom Electrons®

The Bloom Electrons service allows customers to lock in electricity costs for 15 years, delivering predictable costs and significant savings without the upfront capital purchase and ownership of the equipment. Bloom Energy manages and maintains the energy systems; customers only pay for the electricity that is produced.



[Click to Download the Bloom Electrons One-Pager](#)

Operating Lease

The Bloom Energy operating lease, available through Bank of America Merrill Lynch and other similar banks, allows companies to conserve Capex and reduce Opex with a fixed energy cost and predictable payment for 10 years.



[Click to Download the Non-NDA BALC Lease One-Pager](#)

Service Agreements

Regardless of which pricing option customers choose, Bloom Energy is committed to providing customers with operating and maintenance support to ensure the performance of our Energy Servers. Bloom Energy's Remote Monitoring and Control Center constantly monitors each energy system to optimize performance and dispatch certified service technicians for required maintenance.

Contact us today at sales@bloomenergy.com to learn more about the service agreement options available.

Concluding

- **hydrogen will be part of future energy system**
- **adds to energy balance**
- **fits within circular economy**
- **most suitable for seasonal energy storage and transport**
- **commercialization has taken off**
- **further cost reduction required, expected**
- **infrastructure required**