

Autonomous Ship Systems: from Theory to Practice

Ali Haseltalab, Vittorio Garofano, Milinko Godjevac
and Rudy Negenborn

Maritime and Transport Technology Department, TU Delft

An Afternoon with Autonomous Ships at RDM - September 28, 2017

Email: {a.haseltalab, r.r.negenborn}@tudelft.nl

- STW ShipDrive
- STW GasDrive
- STW i-Cave
- NWO Comet-PS
- 'HOP! Let's go outside'

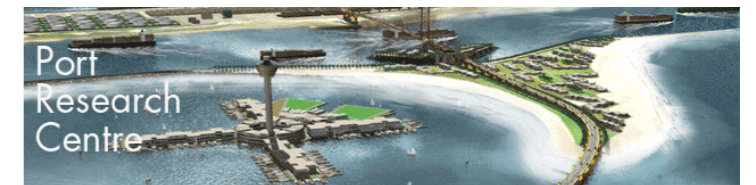

Table of Content

- Introduction
- Scientific Point of View
 - The Concept of Autonomy
 - Autonomous Vehicles
 - Autonomous Vessels
 - Researches at TU Delft
- Practical Point of View
 - The Grey-Seabax
 - Delfia
 - Roboat
 - The Amphibian

I. Autonomous Systems

- From mathematical point of view, an autonomous system is a system which does not explicitly depend on independent variables.



- The advent of autonomous system appertains to the revolution of automation in industry and commerce.



II. Autonomous Vehicles

- Autonomous cars (unmanned ground vehicles) can sense their surroundings and navigate automatically without human input.



- A fully *Autonomous Ship (Surface Vessel)* is a ship which can observe and sense its environment, navigate and maneuver autonomously without human intervention.



III. Autonomous Vessels

Why Autonomy for Vessels?

- Cost reduction of crew
- Cost reduction due to decrease in the speed of voyages.
- Reduced emissions.
- Increased safety: currently more than **75%** of maritime accidents are caused by human errors.
- Increased cargo capacity.



III. Autonomous Vessels

Advent of Autonomous Ships: When?

- Fully autonomous ships are not going to appear over night.
- Several companies have started investigating autonomous vessels.
- Remotely controlled ships will appear in near future in maritime applications.
- Rolls-Royce believe that they can test an autonomous unmanned ocean going ship by 2035.

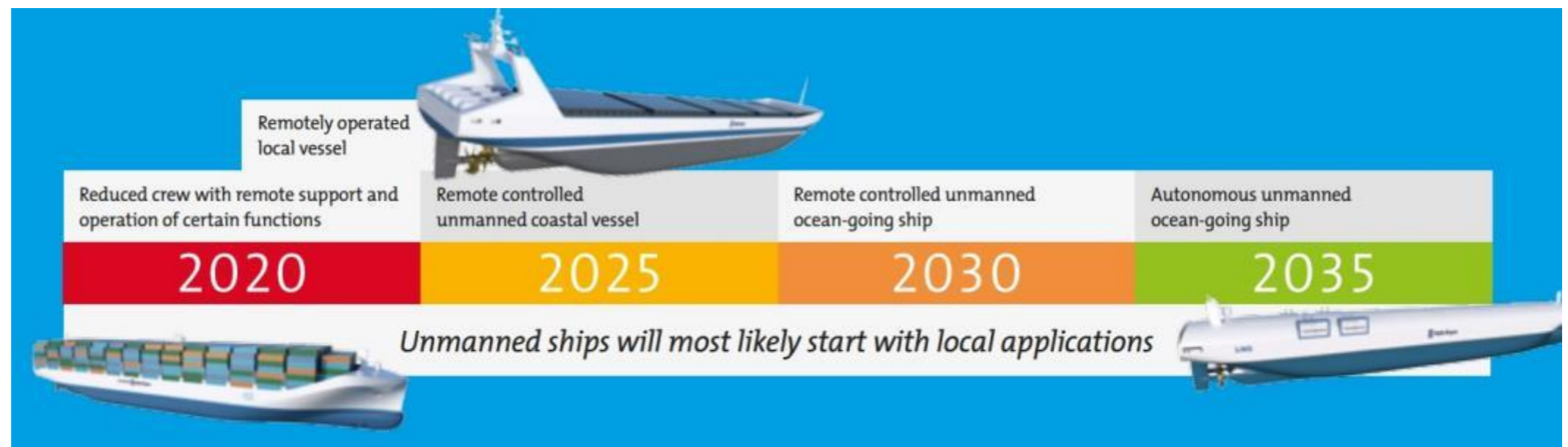

Rolls-Royce Marine

III. Autonomous Vessels

Autonomous Ships: Challenges

- What **technologies** are needed and what should be investigated/created so that autonomous ships can **function robustly** kilometres from shore?
- How can an autonomous ship be made (at least) as **safe** as conventional ships?
- What are the **new risks** with application of autonomous ships?
- Considering the need for more advanced technologies on-board of these ships, what strategies/methodologies can be adopted to **reduce production costs**?
- How to **motivate** ship owners or transport companies to **invest** in autonomous ship systems?
- How should autonomous ships **interact** with each other and also with non-autonomous ones to avoid accidents and reach higher efficiency in carrying out different tasks?
- What considerations should be taken into account so that the on-board **power and propulsion systems** work properly in an autonomous vessels?

These are key challenges of the TU Delft research lines aimed at creating smarter vessels.

IV. Autonomous Vessels: from the Scientific Point of View What Mathematics Can Do in Our Favor?

- Challenge: safe and robust operation.
- To address this issue, several algorithms have been developed/adopted at TU Delft. One is Nonlinear Robust Tube-Based **Model Predictive Control** for ASVs.

$$\dot{\eta}_s(t) = T(\eta_s(t))v(t)$$

$$M_s \dot{v}(t) + C_s(v(t))v(t) + D_s v(t) + d_s(v(t)) = \tau_s$$

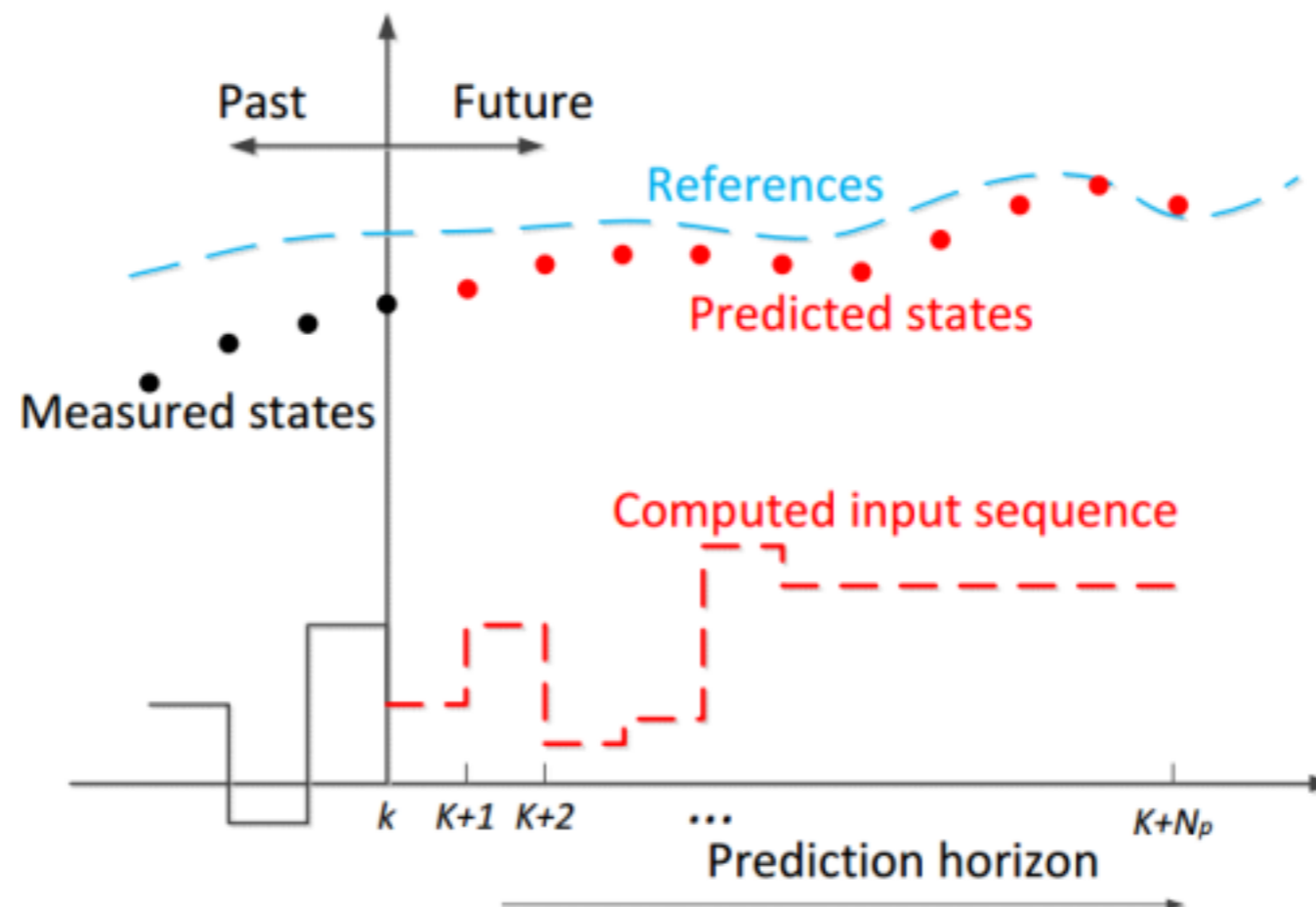

IV. Autonomous Vessels: from the Scientific Point of View

- Two MPC problems are solved; one for nominal system (without disturbances) and the other one for the real system (where disturbances are applied).
- The simplest case example:

$$(M + m_x)\dot{U} = R(U) + T_p(1 - t_d) + T_{\text{ext}}$$

$$\mathcal{P}(Z) : \min_{v_p} j_n(Z, v_p) \quad (1)$$

$$\dot{Z} = f(Z, v_p)$$

$$\beta n_{p_{\min}} \leq v_p \leq \beta n_{p_{\max}}$$

$$\alpha U_{\min} \leq Z \leq \alpha U_{\max}$$

$$\mathcal{P}(U) : \min_{n_p} j(U, n_p) \quad (2)$$

$$\dot{U} = f(U, n_p) + d$$

$$n_{p_{\min}} \leq n_p \leq n_{p_{\max}}$$

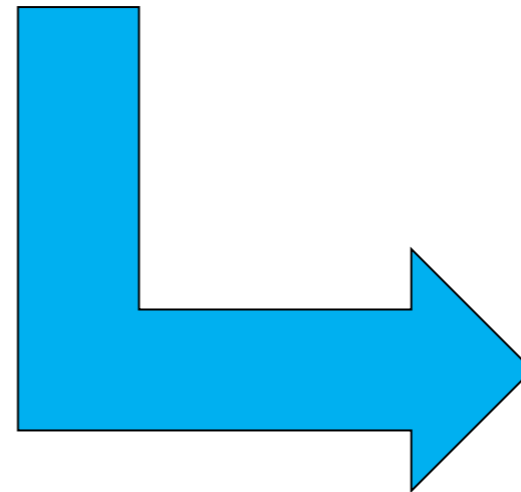

Simulation Results:

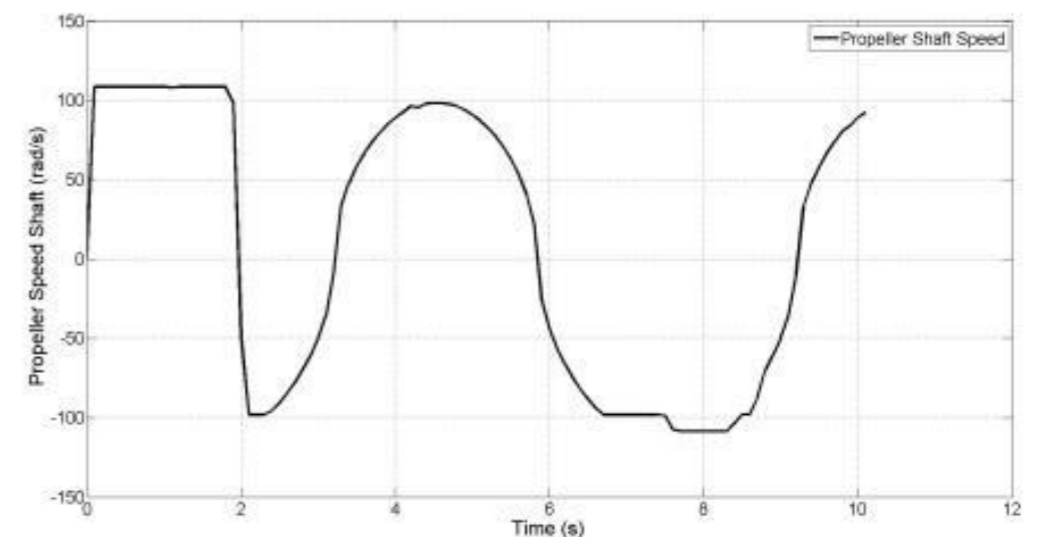
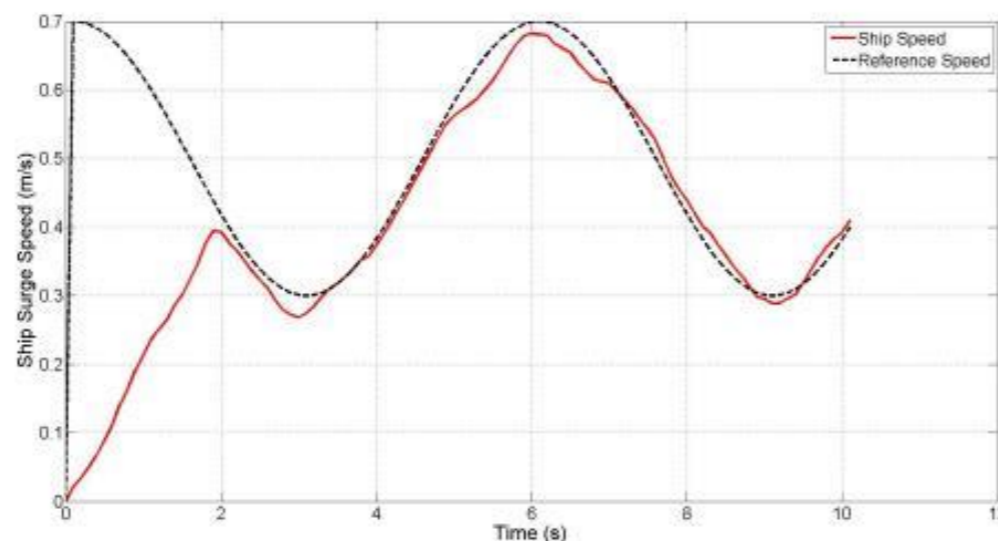

IV. Autonomous Vessels: from the Scientific Point of View

Toward the concept of self-learning autonomous vessels

- Dynamical uncertainties within ships is a challenging problem.
- One of the important uncertainties is within the propellers dynamics of ships.
- We used Neural Networks and Adaptive Control schemes.
- Objective: motion control of an autonomous vessel by real-time estimation of propellers dynamics:

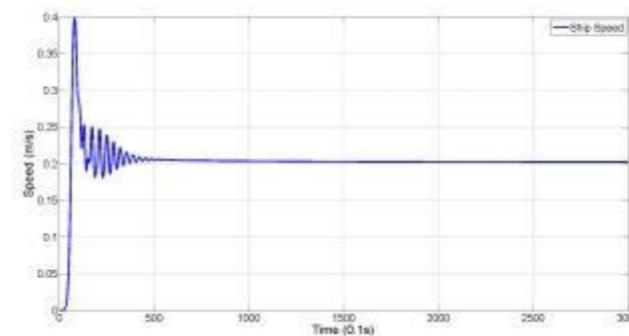
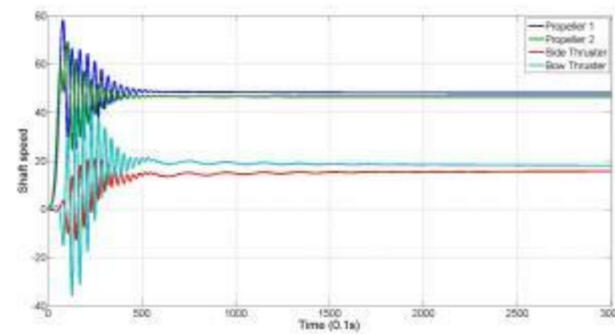
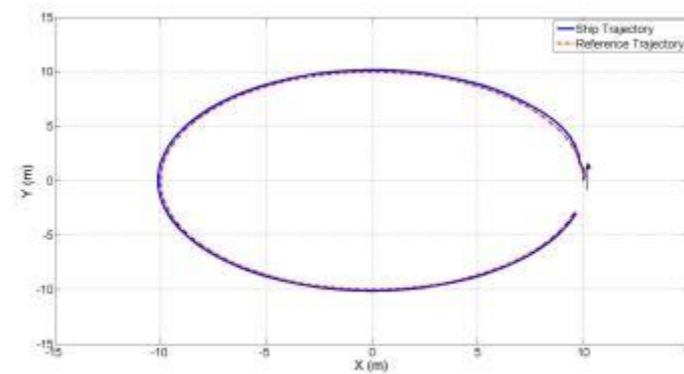
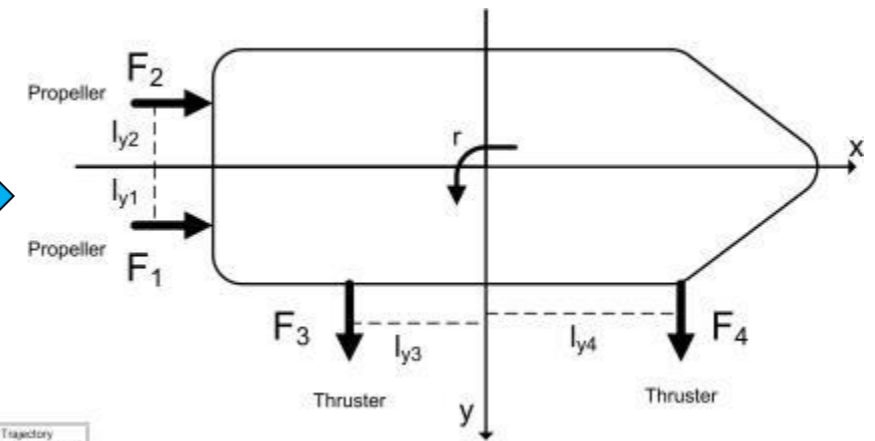
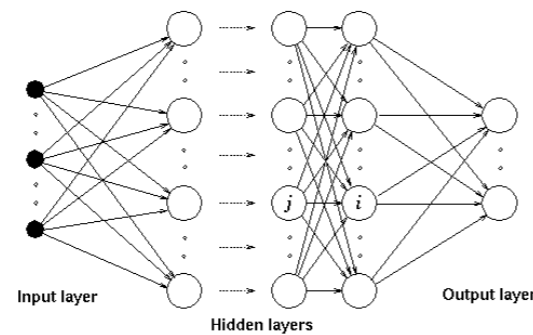

IV. Autonomous Vessels: from the Scientific Point of View

Power and Propulsion Systems in Autonomous Vessels

- What about on-board Power and Propulsion Systems?
- There are several on-going projects at TU Delft such as ShipDrive and GasDrive.

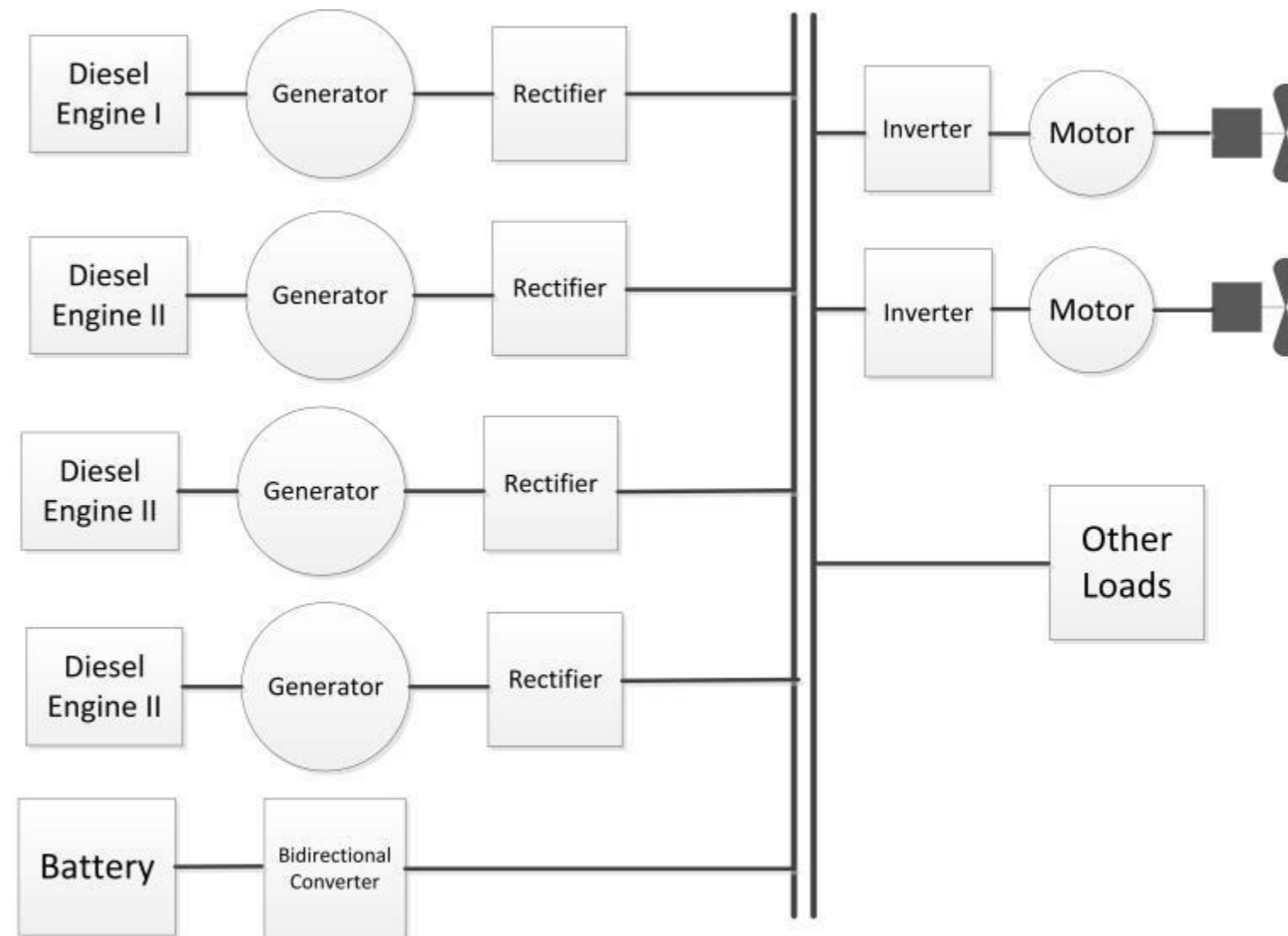

IV. Autonomous Vessels: from the Scientific Point of View

Power and Propulsion Systems in Autonomous Vessels

- Efficiency in terms of fuel consumption is an important issue for autonomous vessels. Several algorithms have been addressed at TU Delft to increase the efficiency of ship power and propulsion systems such as Predictive On-Board Power Management algorithm.

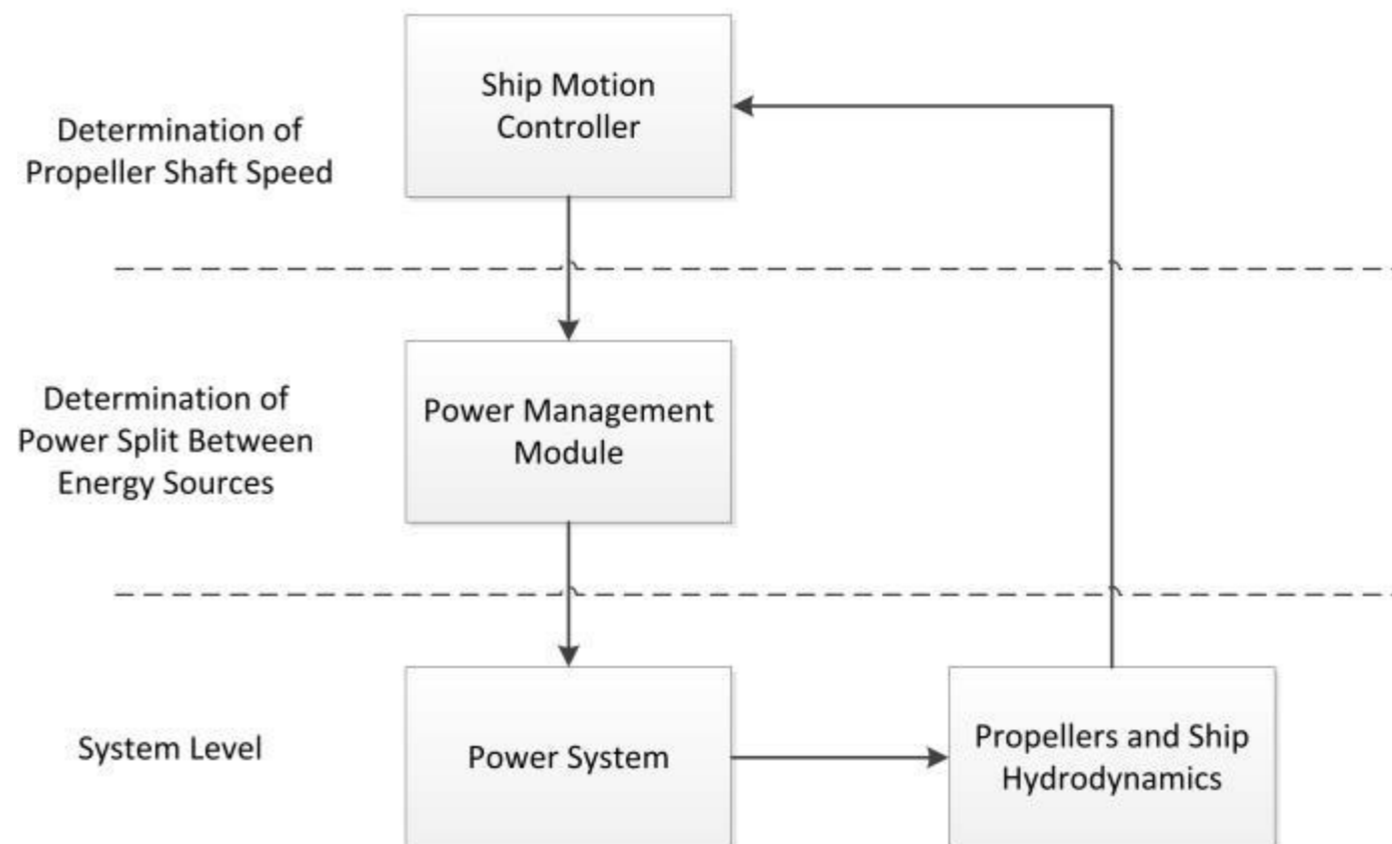

- Health monitoring and fault handling is also another critical challenge. In the context of ShipDrive project, we are investigating Fault-Detection and Isolation algorithms for the ship power and propulsion systems.

IV. Autonomous Vessels: from the Scientific Point of View

Predictive On-Board Power Management algorithm

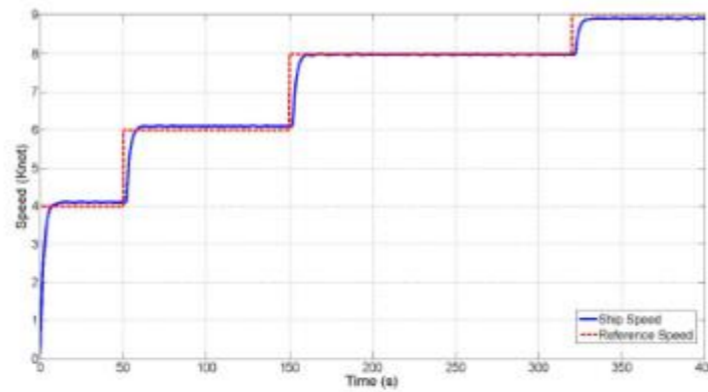

(a) Ship speed

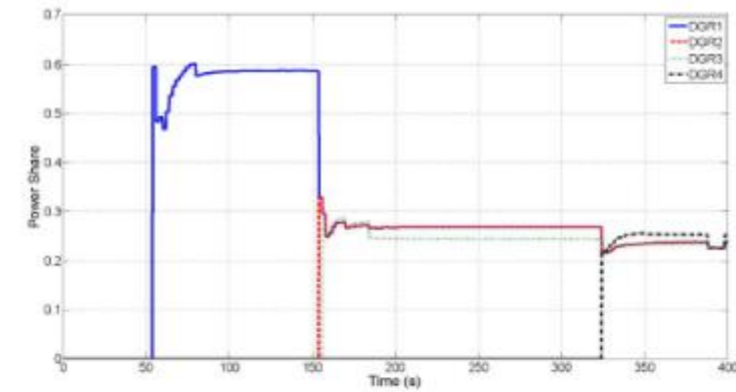

(b) DGRs power share.

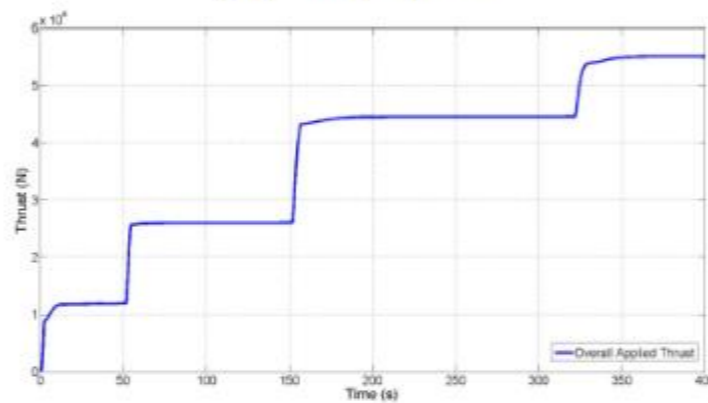

(c) Applied thrust.

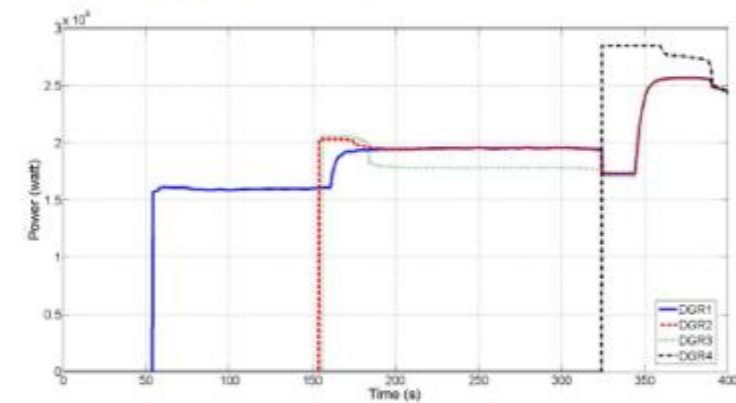

(d) Delivered power by DGRs.

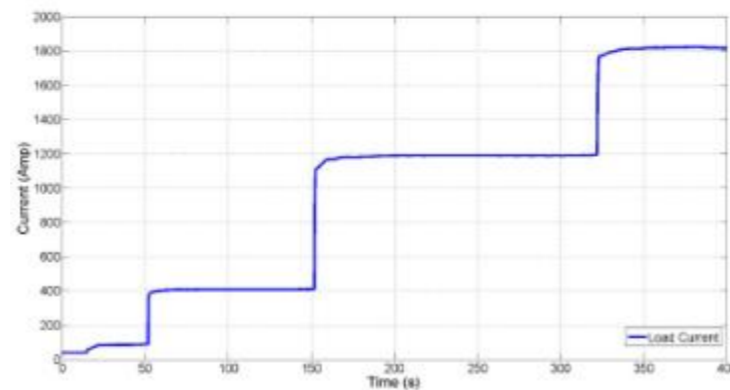

(e) Load currents

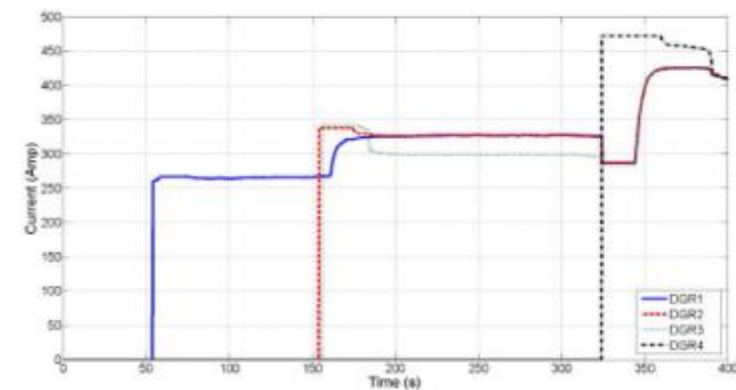

(f) Delivered currents by DGRs

IV. Autonomous Vessels: From the Scientific Point of View Overview

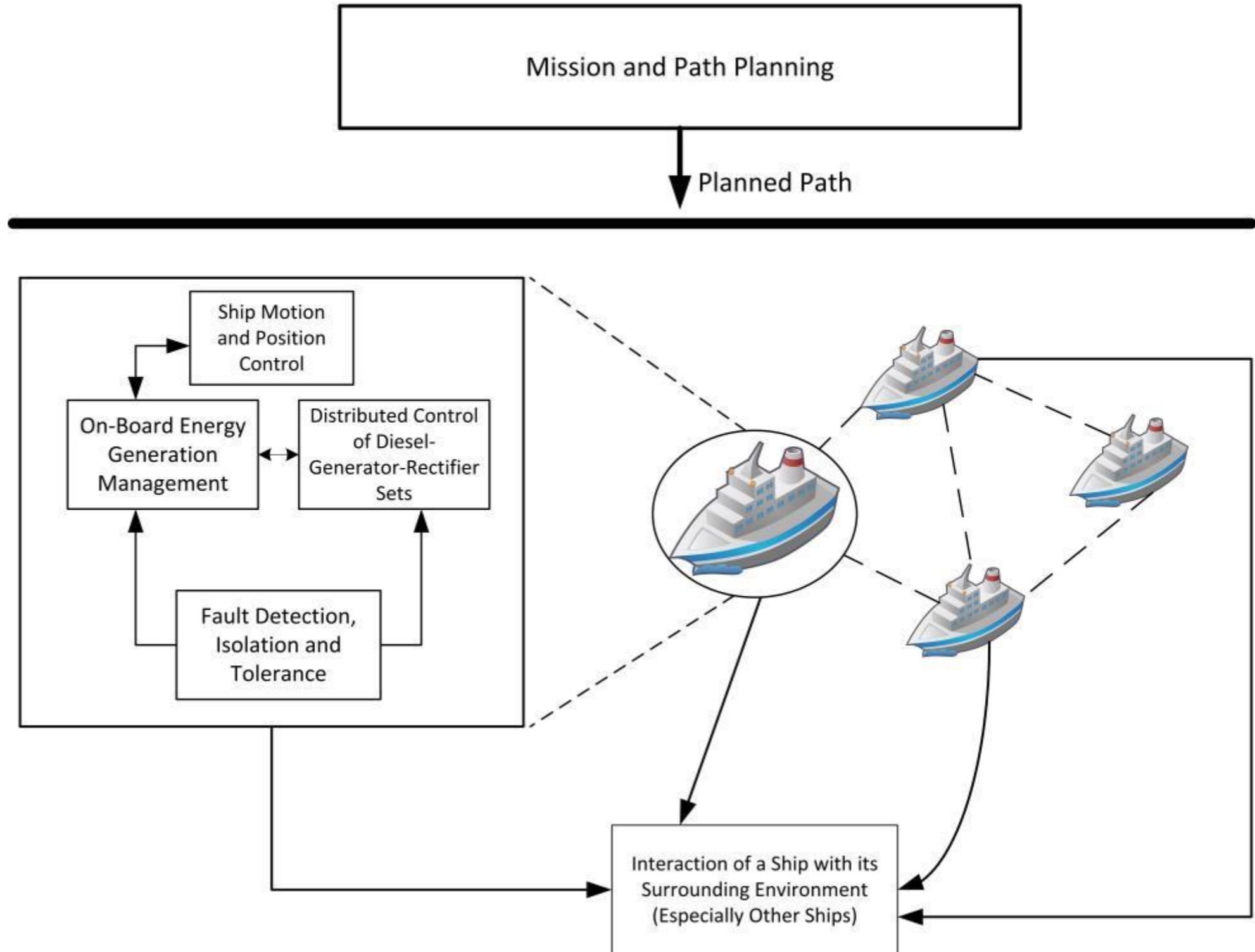

HOW WILL AUTONOMOUS VESSELS WORK?

BENEFITS & CHALLENGES

Autonomous ships are hot. Their development is capturing the enthusiasm of more and more companies. There is a long way to go, but autonomous ships have a great deal of potential. It is not a matter of IF, but only of WHEN they will become a reality. Take a look at the benefits and challenges in this graphical overview.

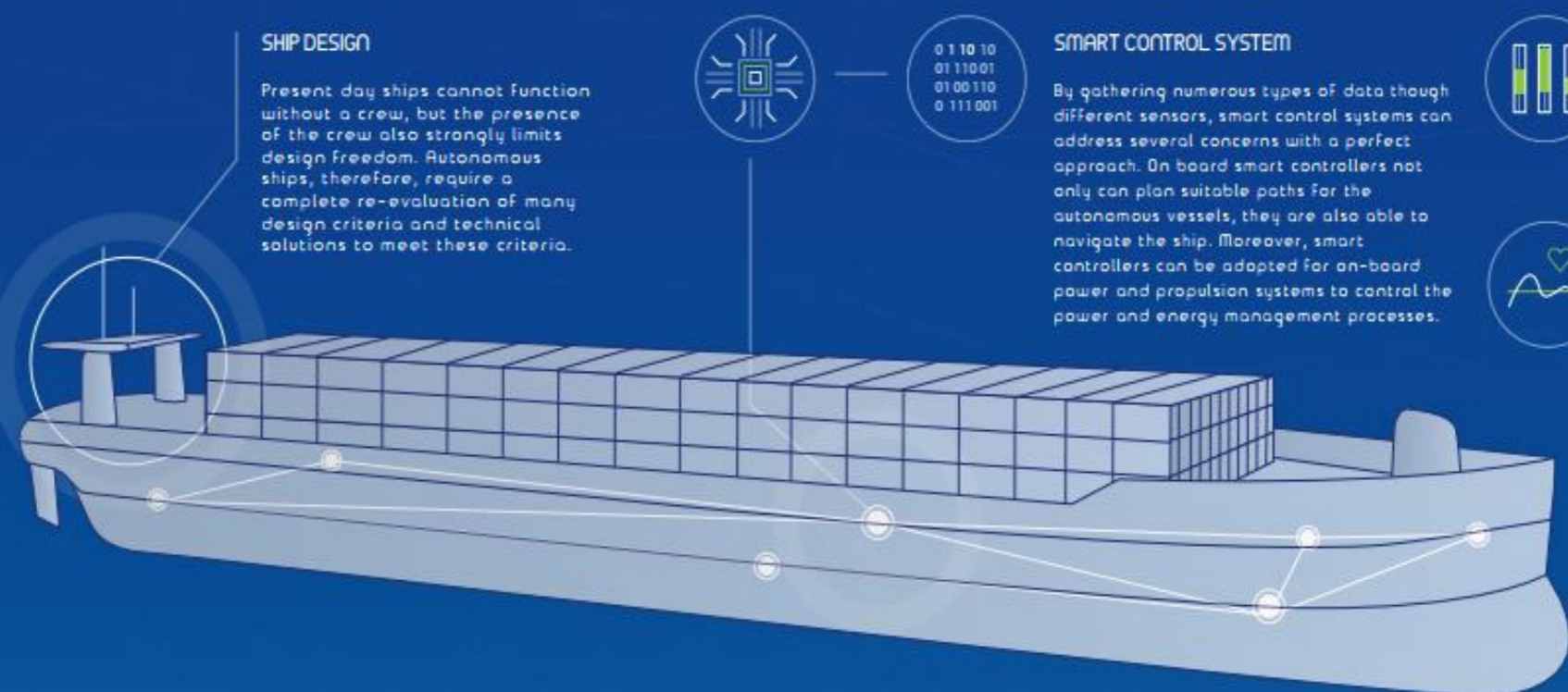

SHIP DESIGN

Present day ships cannot function without a crew, but the presence of the crew also strongly limits design freedom. Autonomous ships, therefore, require a complete re-evaluation of many design criteria and technical solutions to meet these criteria.



0 1 10 10
01 11001
01 00 110
0 111 001

SMART CONTROL SYSTEM

By gathering numerous types of data through different sensors, smart control systems can address several concerns with a perfect approach. On board smart controllers not only can plan suitable paths for the autonomous vessels, they are also able to navigate the ship. Moreover, smart controllers can be adapted for on-board power and propulsion systems to control the power and energy management processes.



CAPACITY

Ships without crew do not require life support systems and can carry more cargo.



HEALTH MONITORING

With the use of different fault-detection and isolation strategies and algorithms, autonomous vessels can detect faults related to different on-board components. In addition, by cooperating with the smart control system the effect of such faults on the overall system can be restricted.

HUMAN ERROR

At least **70%** of all incidents at sea are (partly) caused by human error. Autonomous shipping should therefore lead to a drastic reduction of the number of incidents, casualties and maritime pollution.

LESS CREW COST

For a typical dutch short sea ship, the crew makes up about **40%** of the total costs. Removing the crew therefore has a large potential for cost savings.

TERMINALS

Autonomous ship operations could be aligned with the operations inside automated container terminals so that quay cranes and automated guided vehicles could be scheduled to load/unload and transport containers from the autonomous ships in the most efficient way.

CREW SHORTAGE

By 2025, a shortage of approximately 150.000 maritime officers is expected. Autonomous shipping can help to solve this problem.



AUTONOMOUS COORDINATION

Thanks to distributed control algorithms autonomous vessels are able to collaborate appropriately to carry out different tasks and operations. These vessels are able to communicate and cooperate to optimally operate while several issues such as safety, environmental situations and concerns, fuel consumption and dynamical restrictions regarding to each vessel are considered.

LEGAL

All international ship-related law implicitly or explicitly assumes that ships have a crew and a captain. Changes to the legal framework are, therefore, required to make autonomous shipping possible. Given the way e.g. IMO works, this is a challenging and long-term process.

FLEET LOGISTICS / CONTROL CENTER

Operations of fleets of autonomous ships can be monitored from on-shore control centers; such control centers can moreover be linked to control and supervision centers for road, rail, and air transport, in order to optimize transport chain wide logistics performance.



CONTACT

Rudy Negenborn
r.r.negenborn@tudelft.nl

Robert Hekkenberg
r.g.hekkenberg@tudelft.nl

IV. Benchmarks for Research on Autonomous Vessels

- In order to study dynamical behaviour of autonomous vessels several benchmarks have been developed at TU Delft such as Delfia-1, Delfia-1*, Seabax.

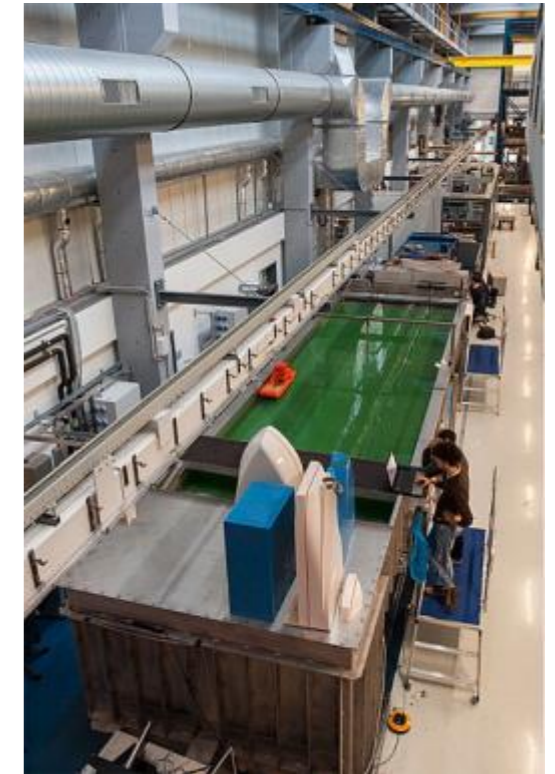

The Grey Seabax: a Remote Controlled Vessel (RCV)

Why:

- Complete a first essential step towards full autonomous ship.
- Have the opportunity to take action in Real-Time;
- Improve traffic management – Increase safety in port terminals – Minimize transport delay



What do we want to achieve:

- Remotely real-time interaction;
- Collect information on the main parameters of the system and take decisions accordingly;
- Provide control signals that will be managed autonomously on board;

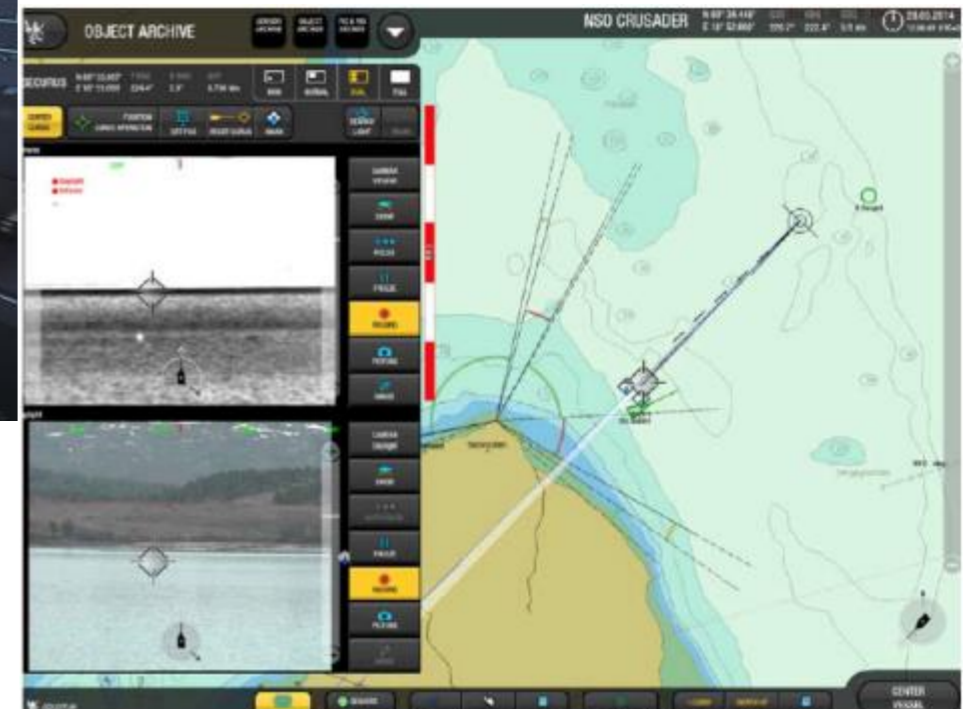

The Grey Seabax:

How:

- Designing a robust communication infrastructure;
- Sensors for feedback signals from the vessel (Sensor data fusion, self-localization, signal analysis and processing);
- A real application based on the equations describing its motion.



TITO NERI for Dynamic Positioning Experiments

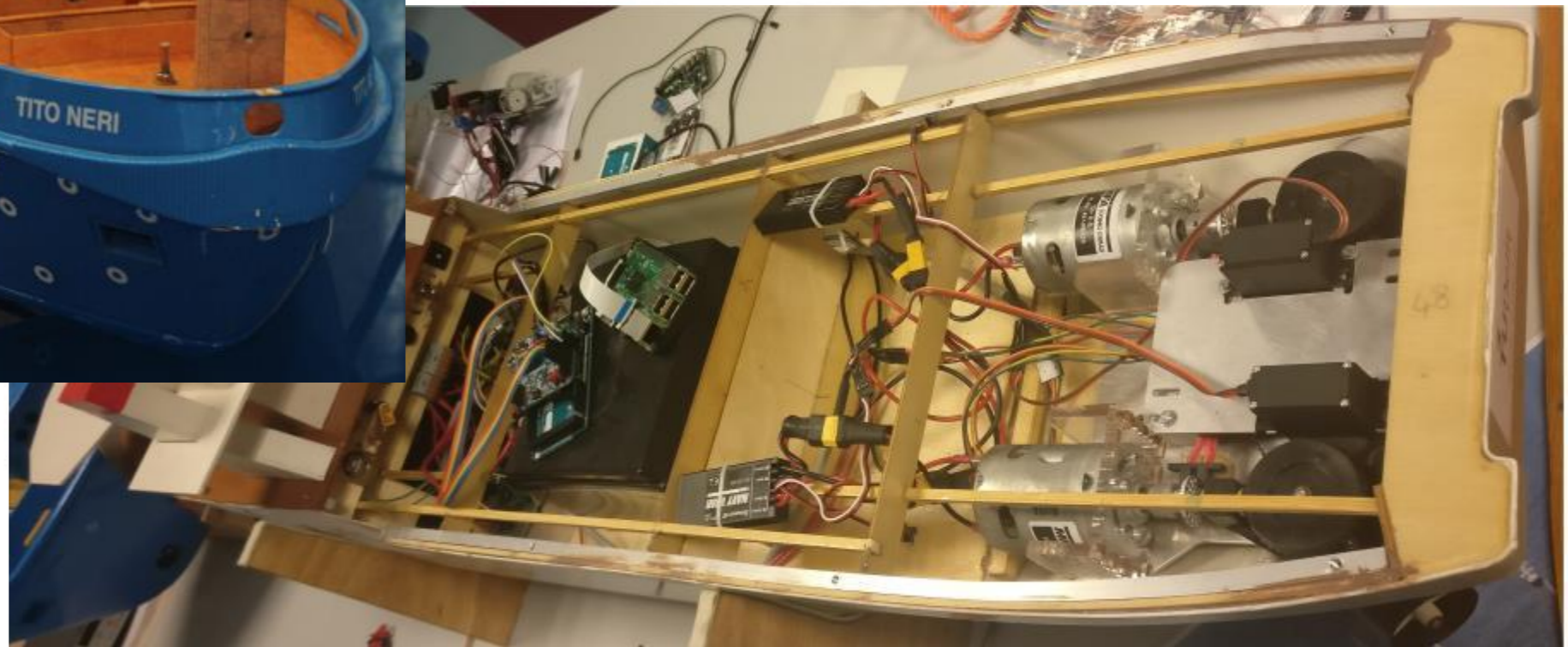
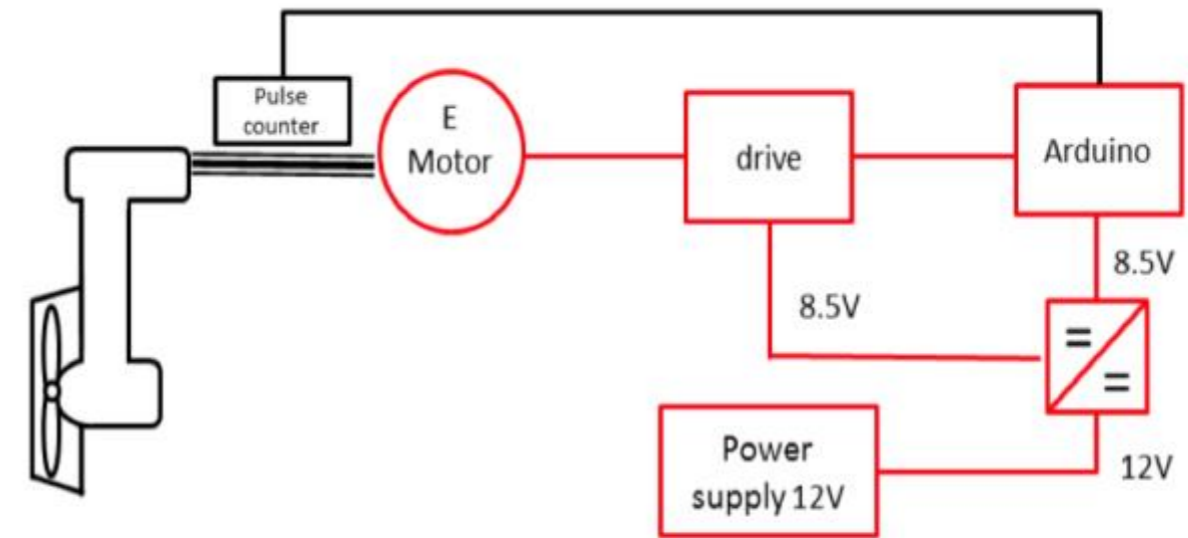
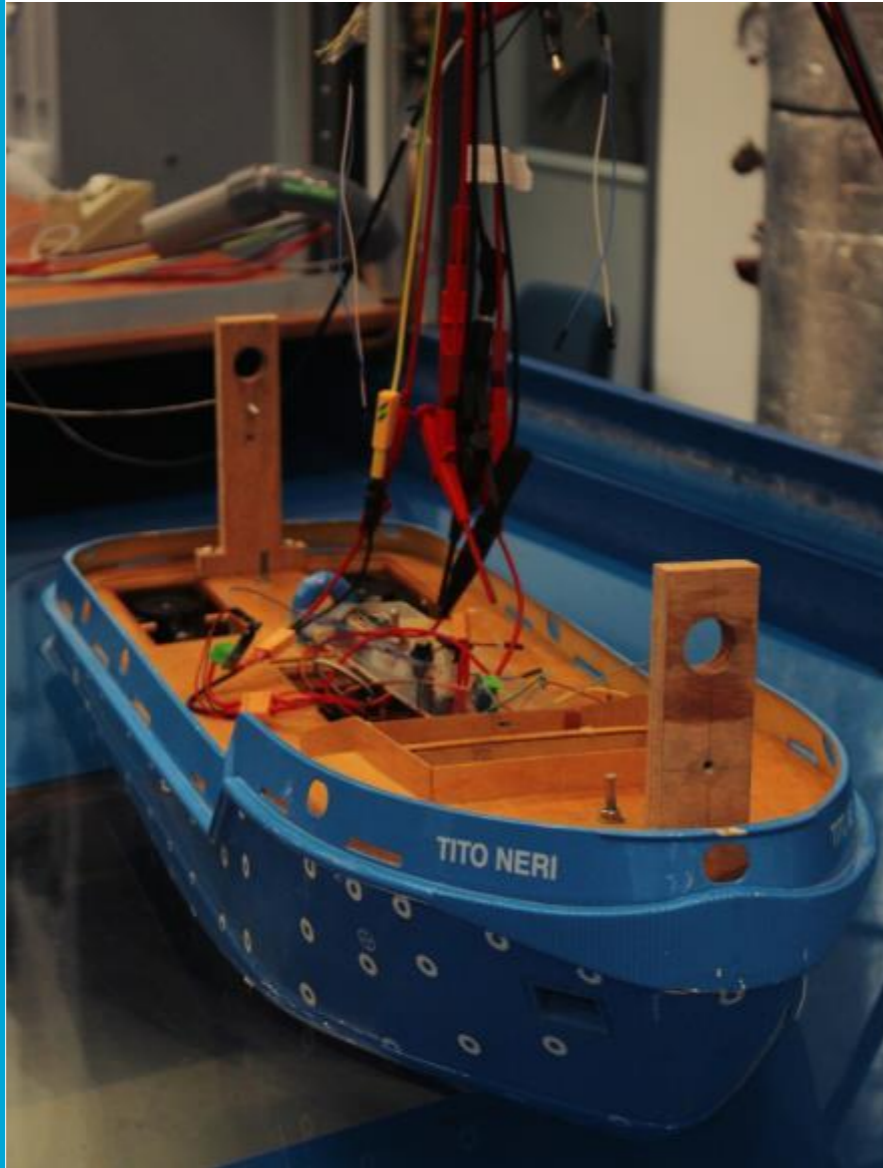

Delfia:

A Benchmark For Analyzing Collective Behavior Of Autonomous Vessels

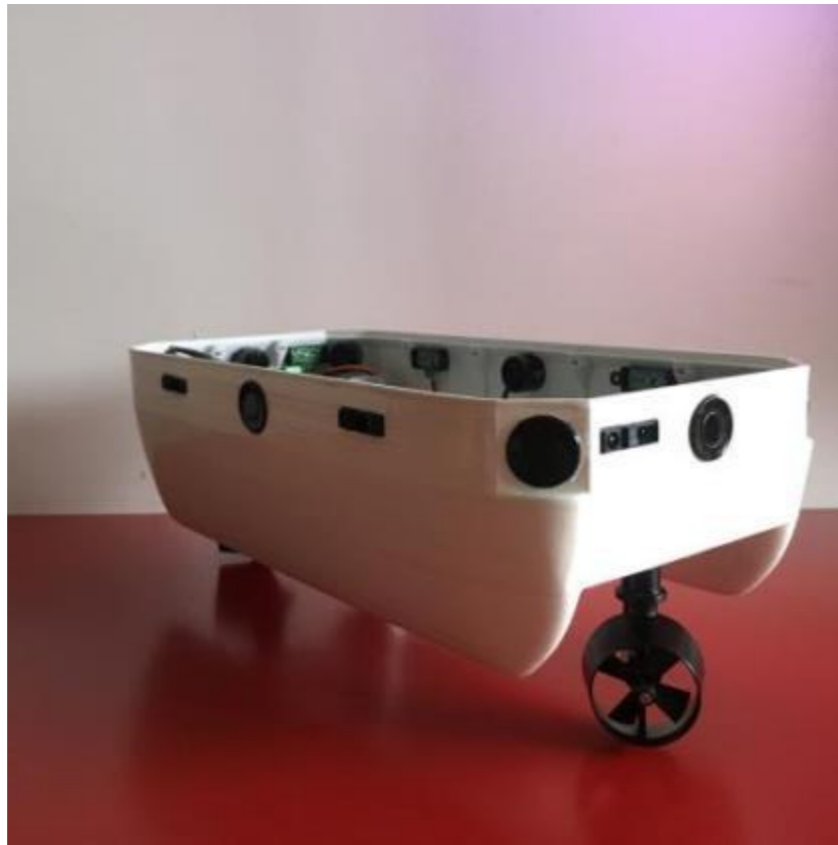

Delfia:

From Centralized to Distributed Control

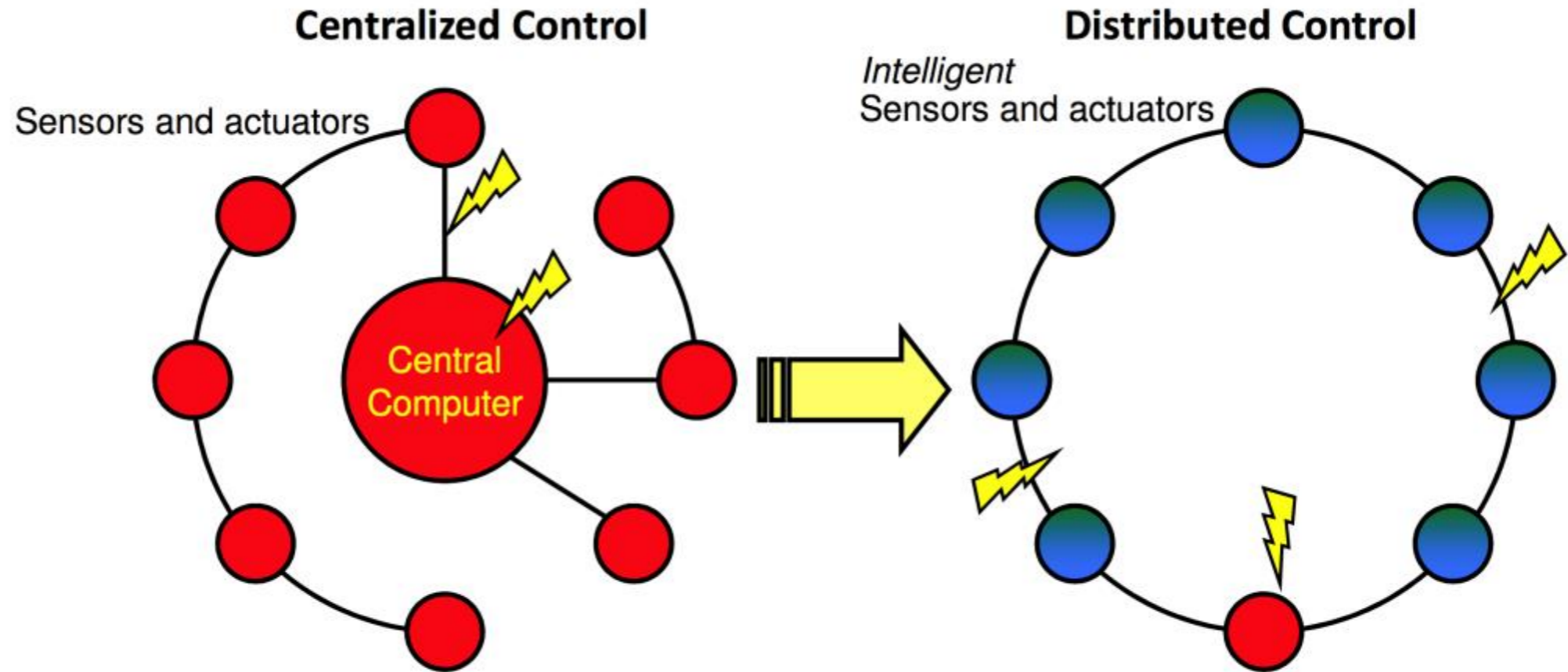

“More autonomy on a lower level results in increased survivability”

Roboat:

Amsterdam Autonomous Boats

- A fleet of autonomous boats in Amsterdam's canals, monitoring the environment, providing transportation and enabling self-assembling bridges and other urban infrastructures.
- Roboat is the world's first major research program on autonomous floating systems that focusses on moving people and goods, portable infrastructure and data gathering.



- Amsterdam Institute For Advanced Metropolitan Solutions (AMS)
- MIT
- TU Delft
- WUT

The Amphibian:

A Futuristic Vision To Explore New Transportation Routes

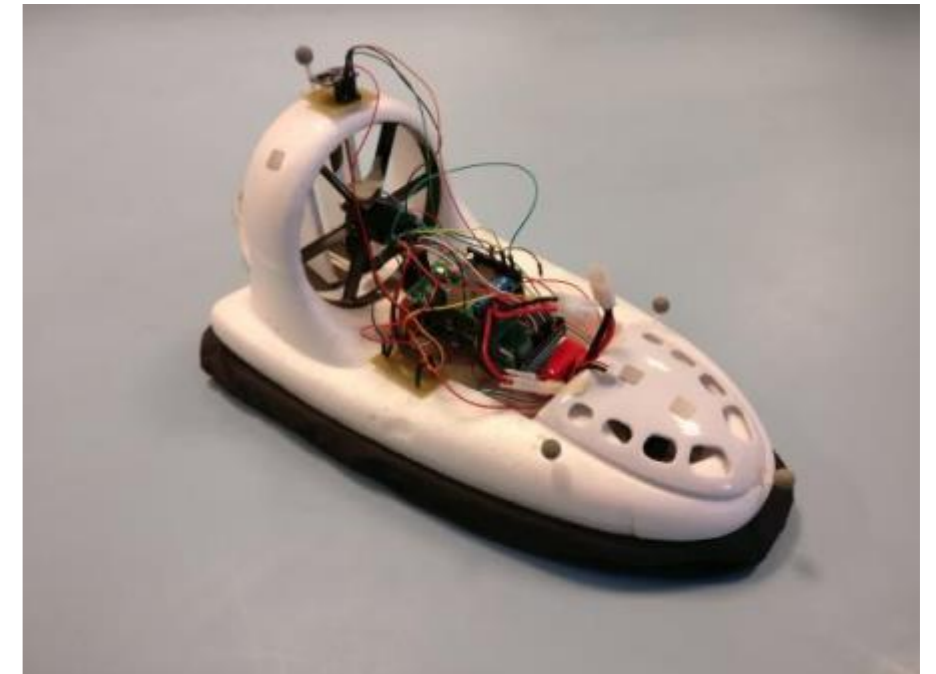
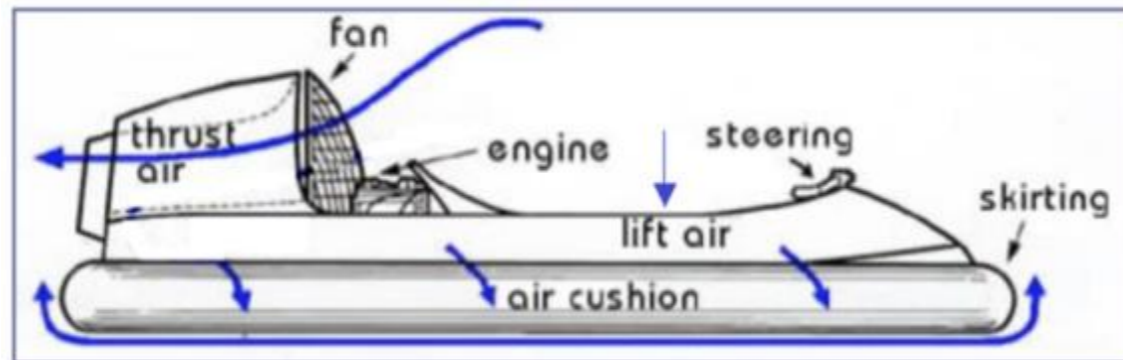

Challenges:

- Non-linearity in the mathematical equations;
- Under actuated system;
- Very low friction.

Thank You for Your Attention

