



Design & building of high-end vessels for offshore & dredging

G. Hamers
16 juni 2009



The technology innovator.



IHC Merwede focuses on niche markets in which it can serve customers with value add maritime work tools

- **Ships**
 - Custom-built, Complex, focus on Engineering
 - Standard Beaver Range
 - Continuous Development
 - World wide customer base
- **Ship and Systems**
 - Integrated Product
 - Newbuild
 - After Sales Service: life cycle support
- **Products and Systems**
 - Technology & Services
- **Markets**
 - Dredging
 - Offshore Construction
 - Renewable energy
 - (Deep Sea) Mining



A key objective of IHC Merwede is to contribute to lowering its customers' operational costs

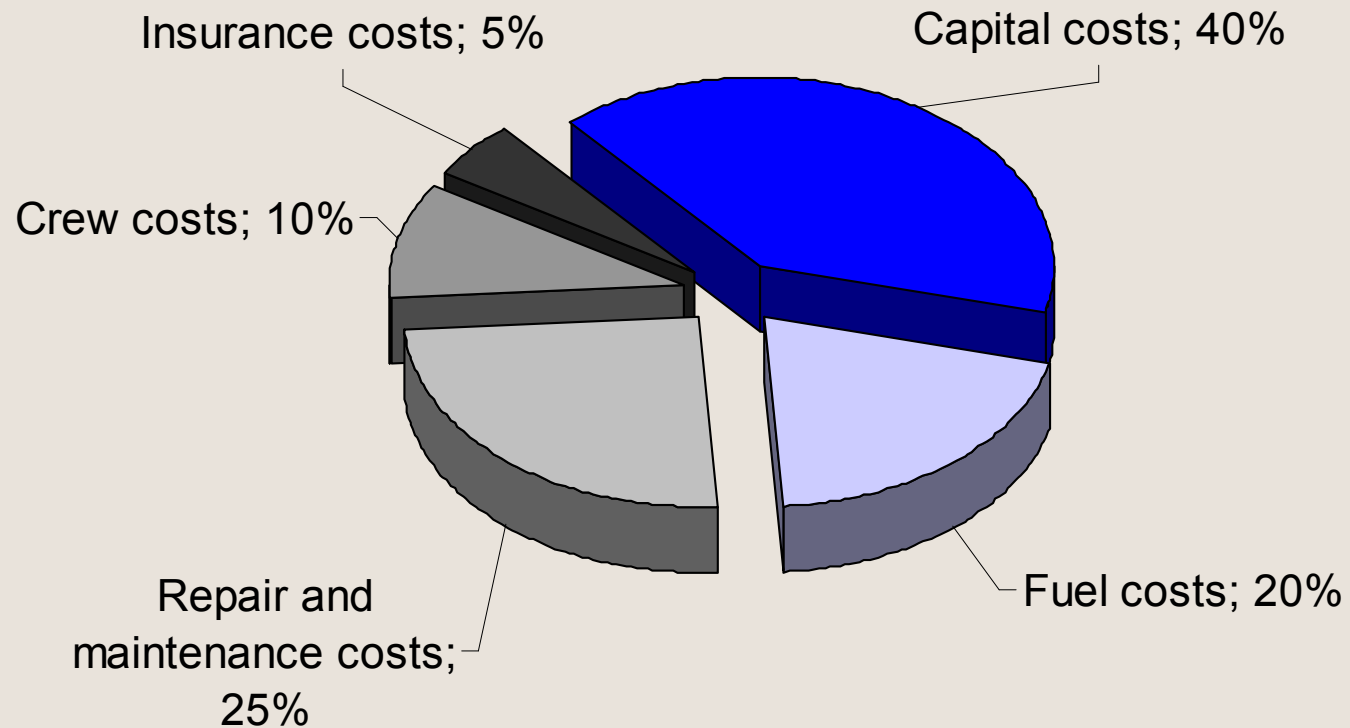



Through its decentralized organisation, IHC Merwede fosters strong local entrepreneurship and authority





IHC Merwede has branches across the globe





IHC Merwede is the clear world market leader in the design and build of dredging vessels





IHC Merwede is a recognized builder of high-end offshore vessels





IHC Merwede has a full range of dredging systems and components





IHC Systems designs and builds integrated system automation & control units

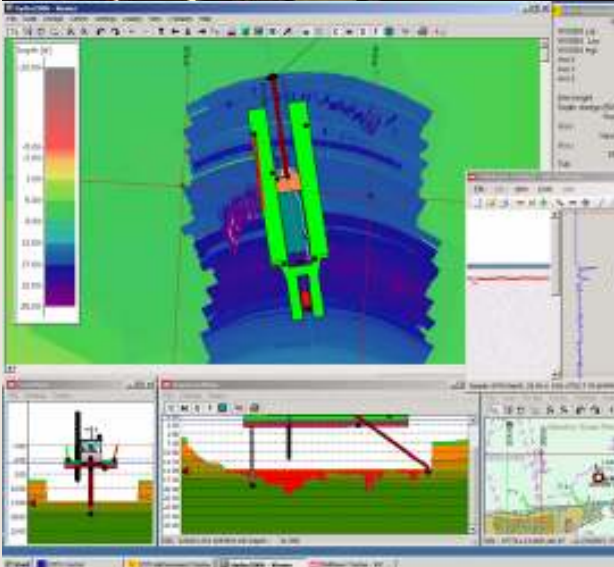



IHC Merwede is a designer and supplier of offshore equipment and components





IHC Merwede is a designer and supplier of offshore equipment and components

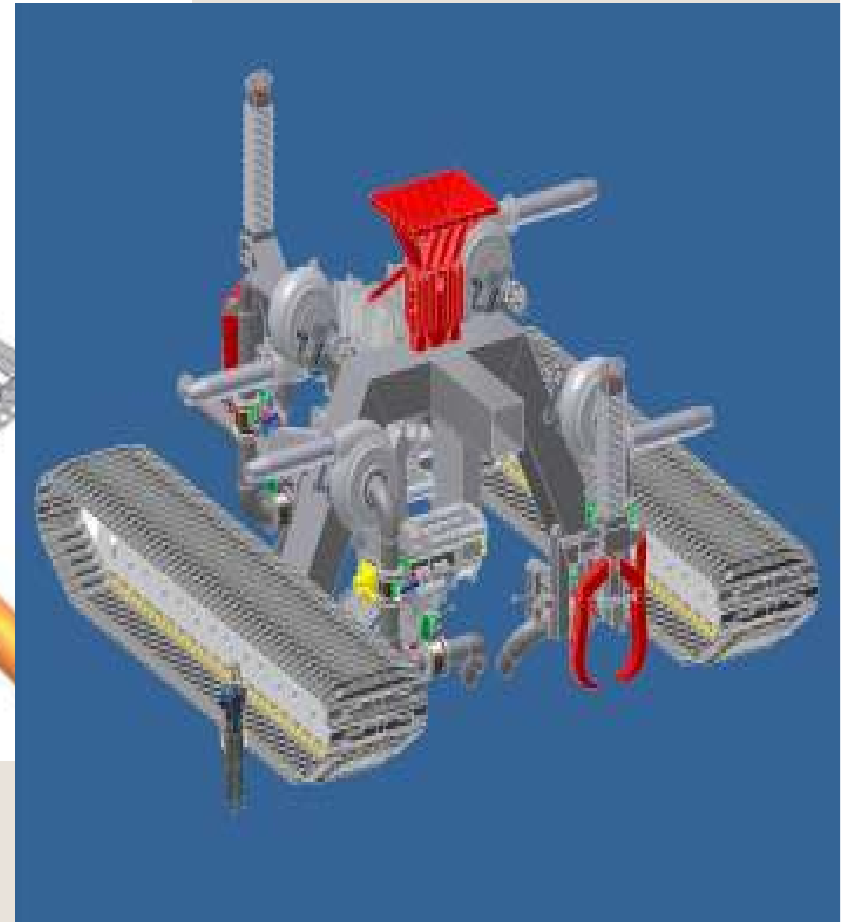
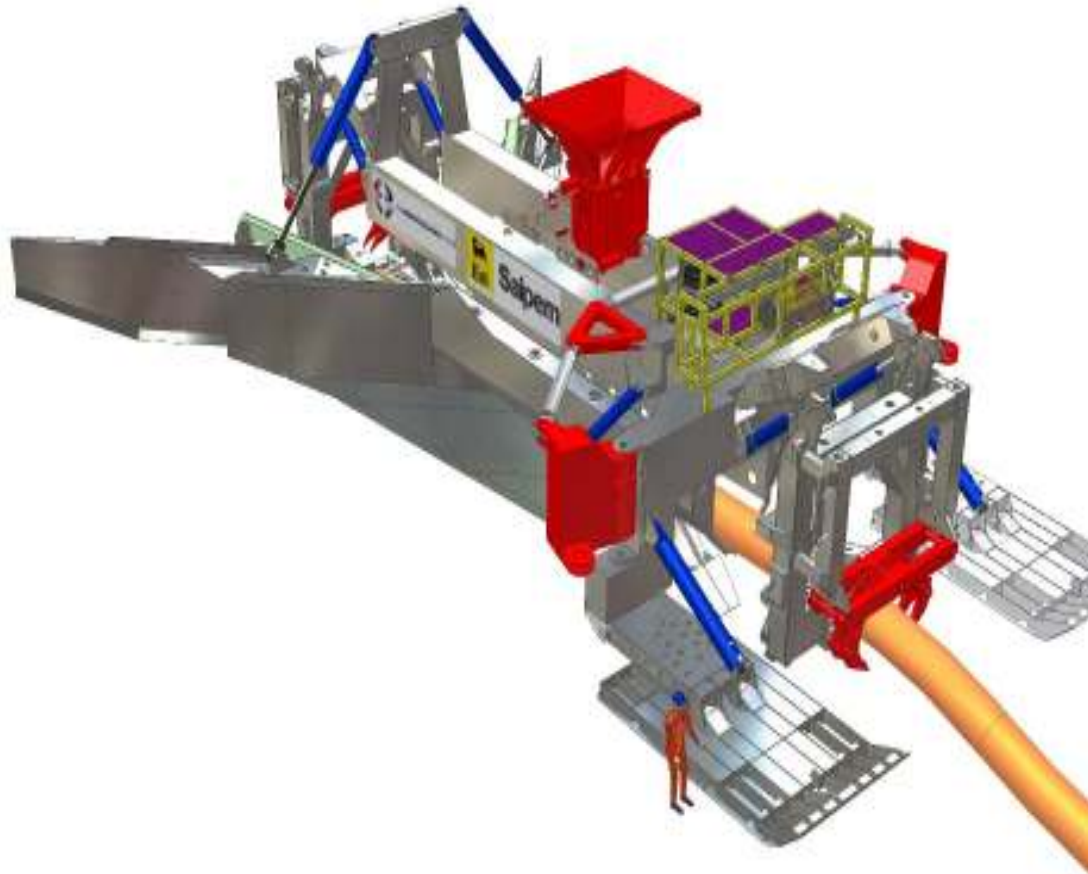



IHC Merwede is a designer and supplier of offshore equipment and components



Heave compensator by IHC Hytop



Offshore: overall demand





Investments in the offshore oil & gas market have seen steady growth over the years

Total Capex in development of offshore oil & gas fields

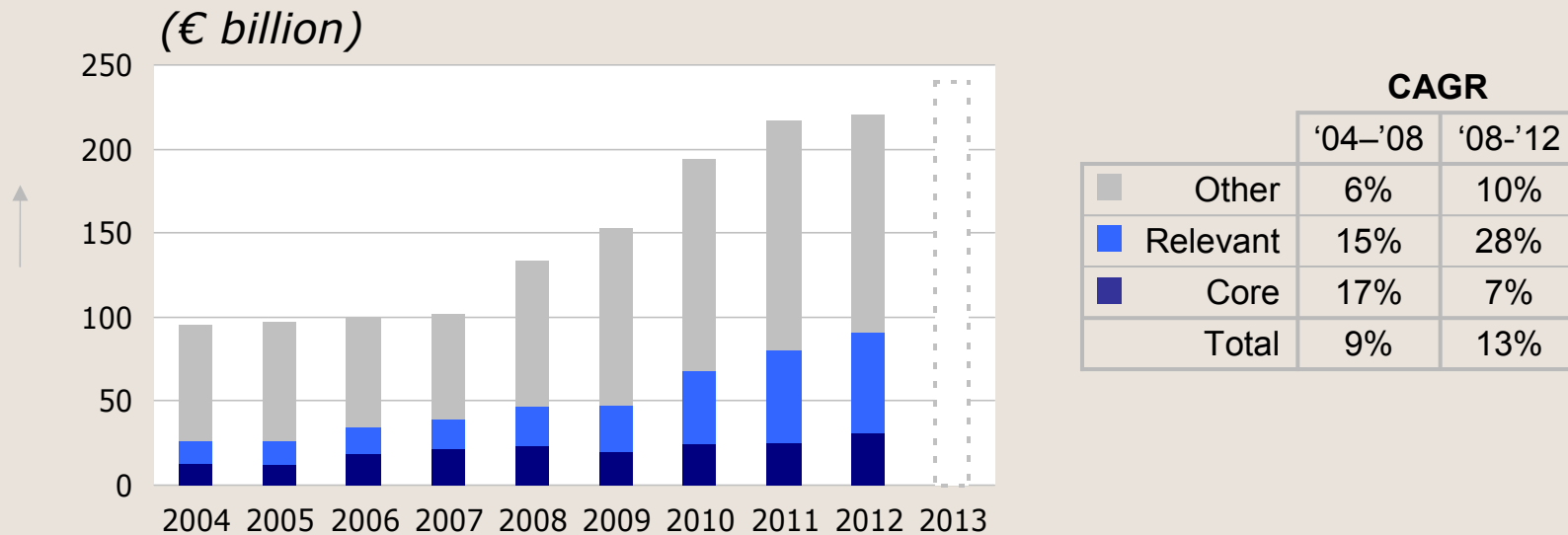

- The offshore oil & gas market has seen steady growth over the last few years
- Despite the current down cycle, future annual growth of Capex on development of oil & gas fields is expected to be 11% until 2012, since the major investments in offshore are long-term and high-order, and therefore less influenced by (short-term) effects



Latin America and West Africa will offer the largest demand in the short to medium term

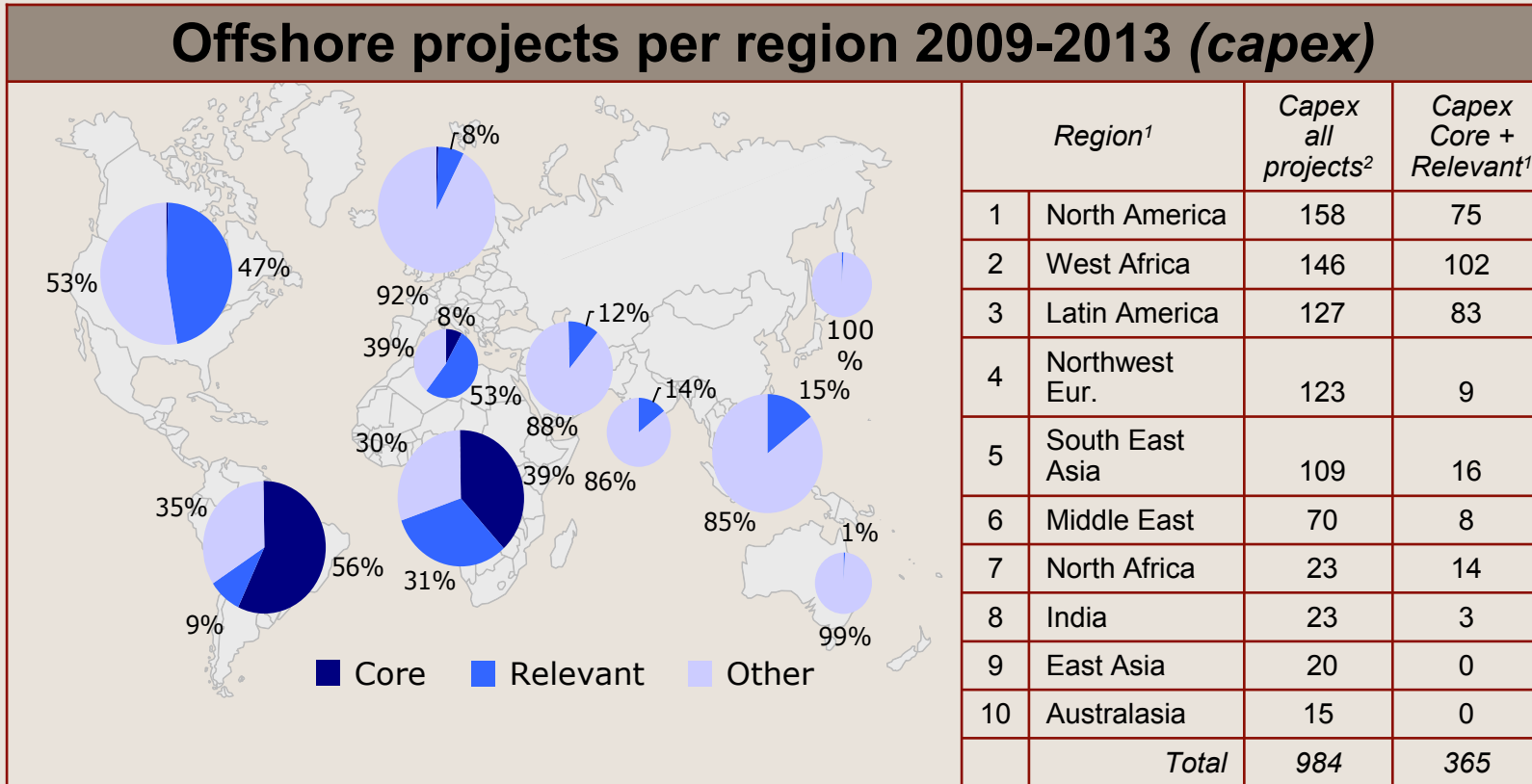

- North America, West Africa, Latin America and Northwest Europe are the main offshore regions
- Latin America and West Africa are the two most interesting regions regarding development of Core projects (the segment in which IHC Merwede vessels can best differentiate)
- Investment growth in projects in deep water, harsh weather conditions and high HSE standards will accelerate; a growth opportunity for IHC Merwede



Dive support and drilling have the highest overall demand for the coming years

Residual demand (2009-2013) in vessel days per ship functionality

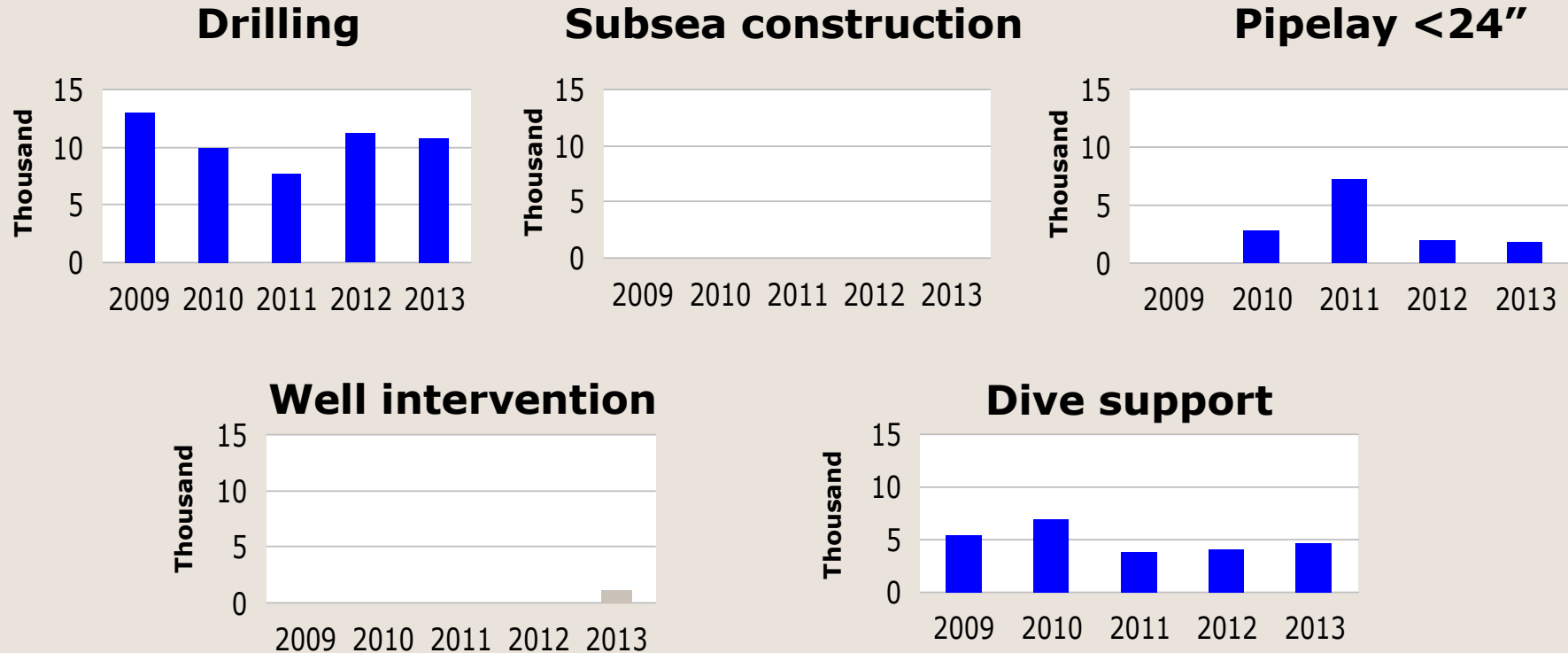

- Drilling and dive support have the highest residual demand for the coming years
- Pipe lay vessels will be in demand but to a (somewhat) smaller extend than dive support and drilling
- IHC Merwede sees a medium to long term opportunity in heavy well intervention



Future Developments Offshore





Future Developments Offshore

IHC Merwede focus on 6 types of high-end vessels & its components:

- 1. Pipe layers**
- 2. Diving support vessels**
- 3. Well intervention / drill ships**
- 4. Deep sea mining ships & mining equipment**
- 5. Wind-turbine generator installation vessels**
- 6. Integrated modular multi-purpose offshore vessels**

Future Developments Offshore

1 Pipe layers

- Safer, less crew costs by high level of automation, higher productivity
- All technologies available within IHC Merwede & partners
- Truly integrated pipe-laying vessel



Seven Oceans

Length	157 m
Speed	15 kn
Total installed power	21,700 kW
Operating depth	3000 m



Seven Seas

Length	153 m
Speed	15 kn
Total installed power	21,700 kW
Operating depth	3000 m

Future Developments Offshore

2 Diving support vessels

Highly complex & integrated design and turnkey delivery



Toisa Pegasus, Diving Support Vessel (2008)

Length: 132 m, Weight: 9440 t, Max. operating depth: 300 m

Total installed power: 13.1 MW, Cranes: 400 t @ 3000 m water depth



Future Developments Offshore

3a Well intervention

Medium to heavy well-intervention ships.

All technologies available within IHC Merwede & partners

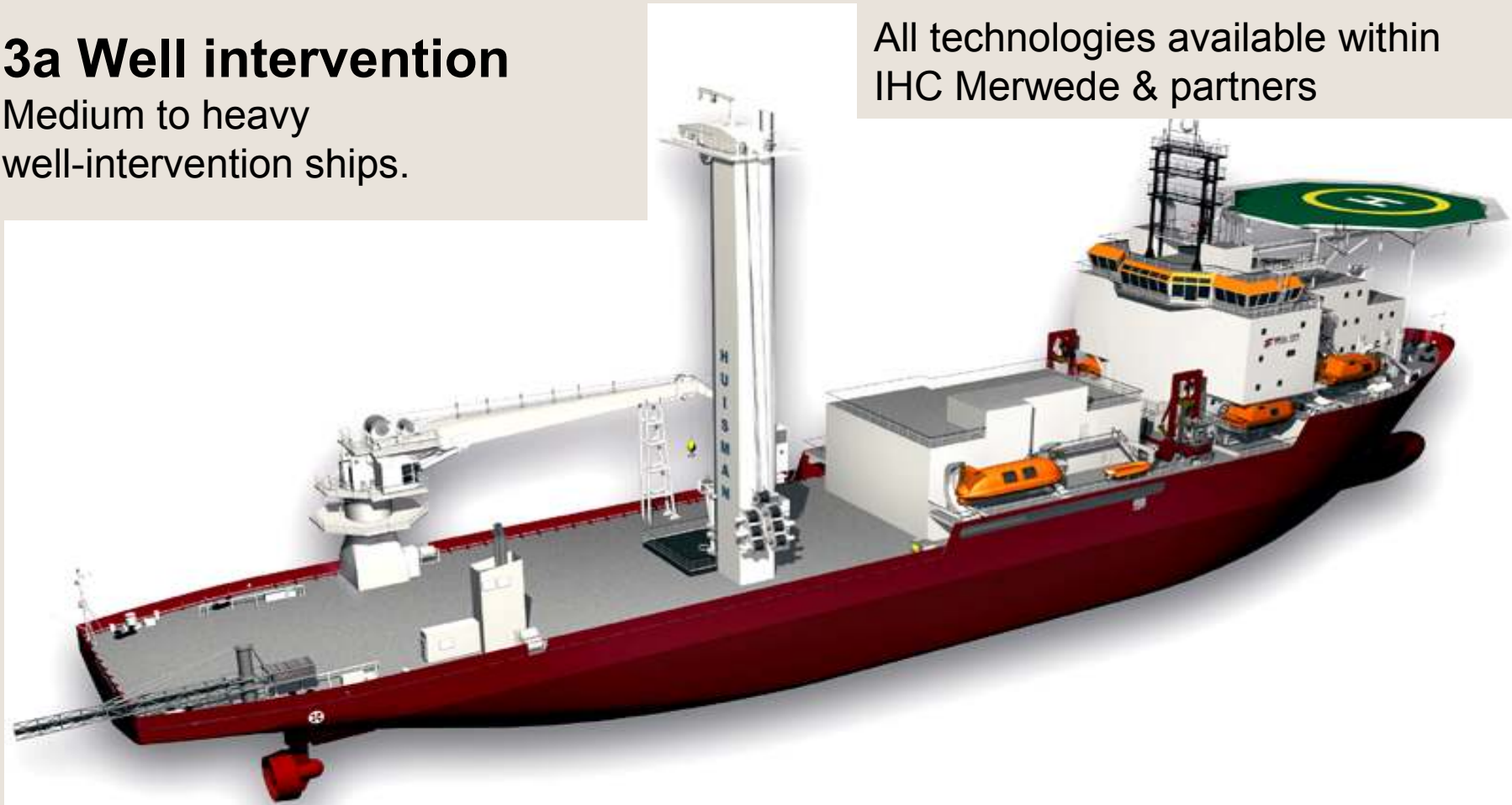

Well Enhancer, Well intervention/ diving support vessel

(2008) Length: 132 m, Weight: 7950 t, Max. operating depth: 300 m
Total installed power: 15.9 MW, No. of divers: 18, No. of dive bells: 2



Future Developments Offshore

3b Drilling vessels

Compact integrated design.

All technologies available within IHC Merwede & partners



P-3672, Drilling vessel

Length: 189 m, Weight: 30000 t, Max. Drilling depth: 10000 m
Total installed power: 34 MW, Max. water depth: 3000 m

Future Developments Offshore

Dredging & mining developments





Future Developments Offshore

4a Deep sea mining ships & equipment

Focus on ultra deep water & high capacity mining operations.

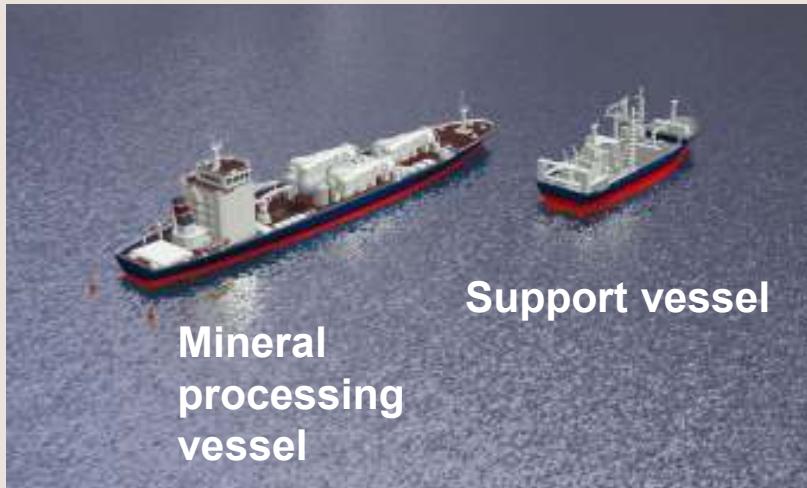

Pump units
50 MegaWatts

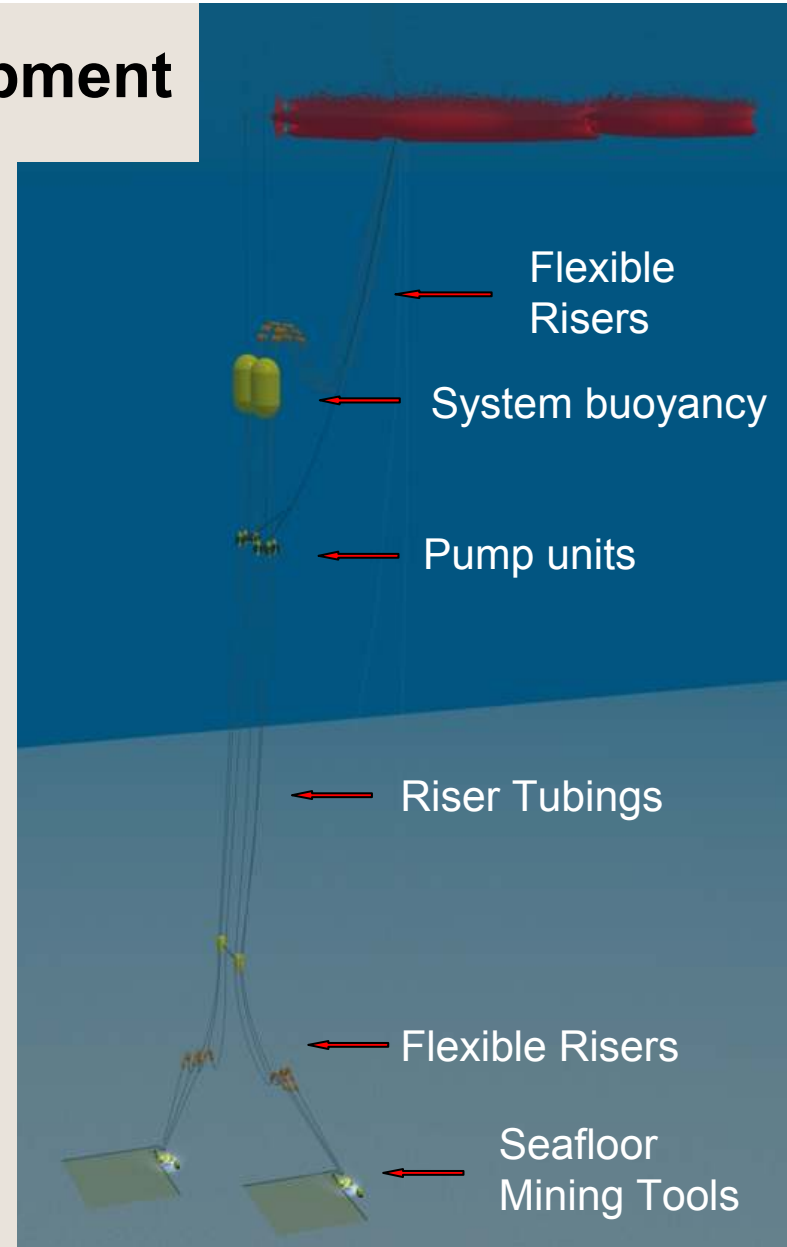

Future Developments Offshore

4b Deep sea mining ships & equipment

Focus on ultra deep water & high capacity mining operations.

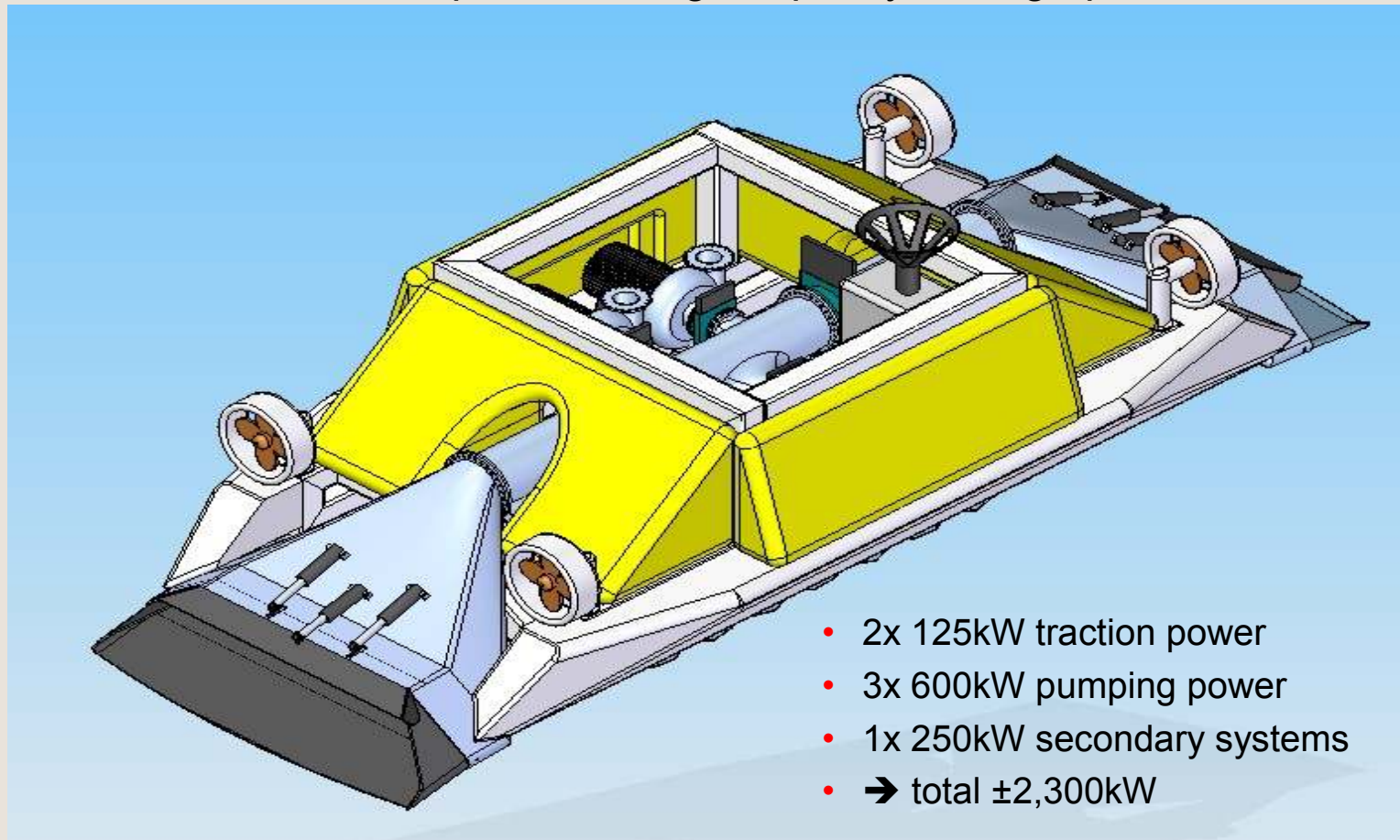

- 2x 125kW traction power
- 3x 600kW pumping power
- 1x 250kW secondary systems
- → total $\pm 2,300$ kW

<Concept>, Seabed mining tool

Max. water depth: 4000 m

Future Developments Offshore

4c Deep sea mining ships & equipment

Focus on ultra deep water & high capacity mining operations.

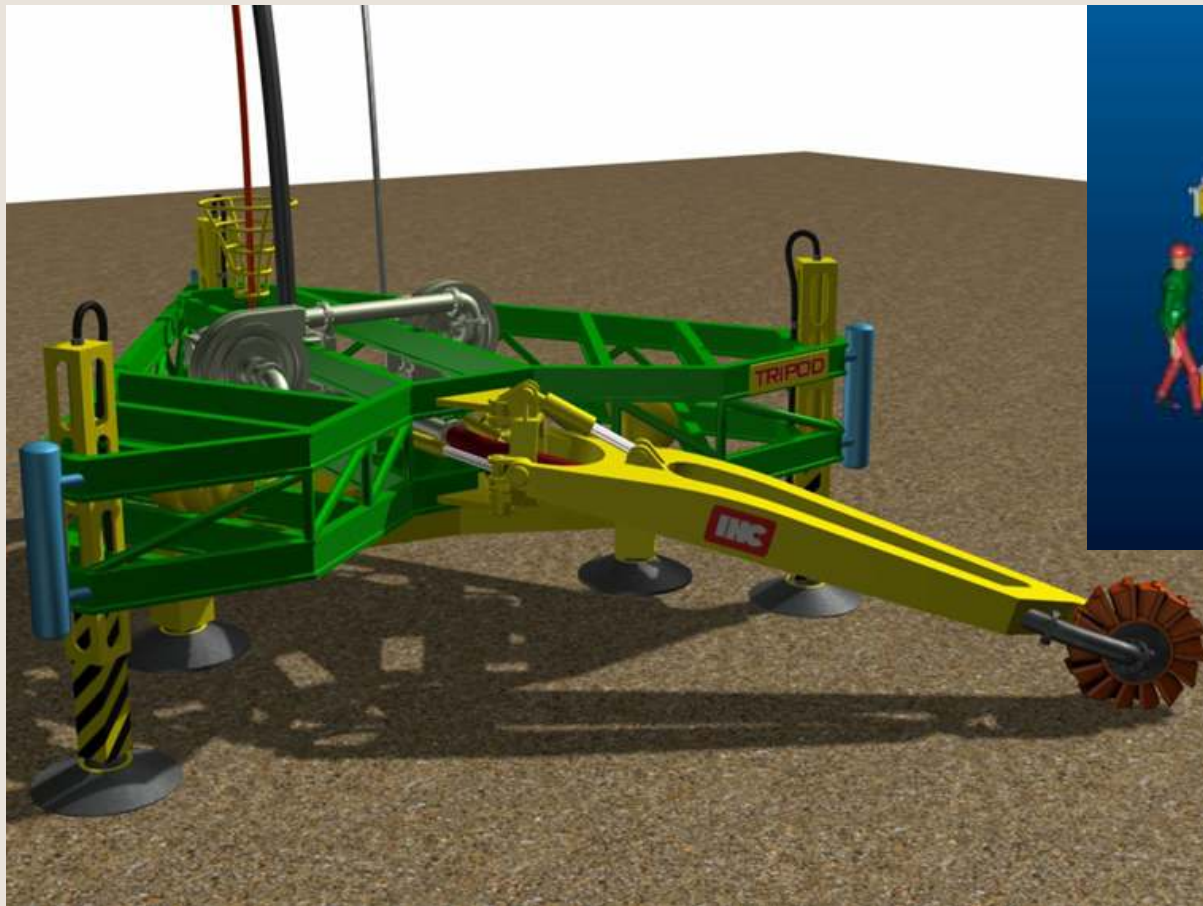

<Concept>, Deep-sea mining tool

Max. water depth: 4000 m



Future Developments Offshore

5a Wind-turbine Installation vessels

Integrated design and
turnkey delivery

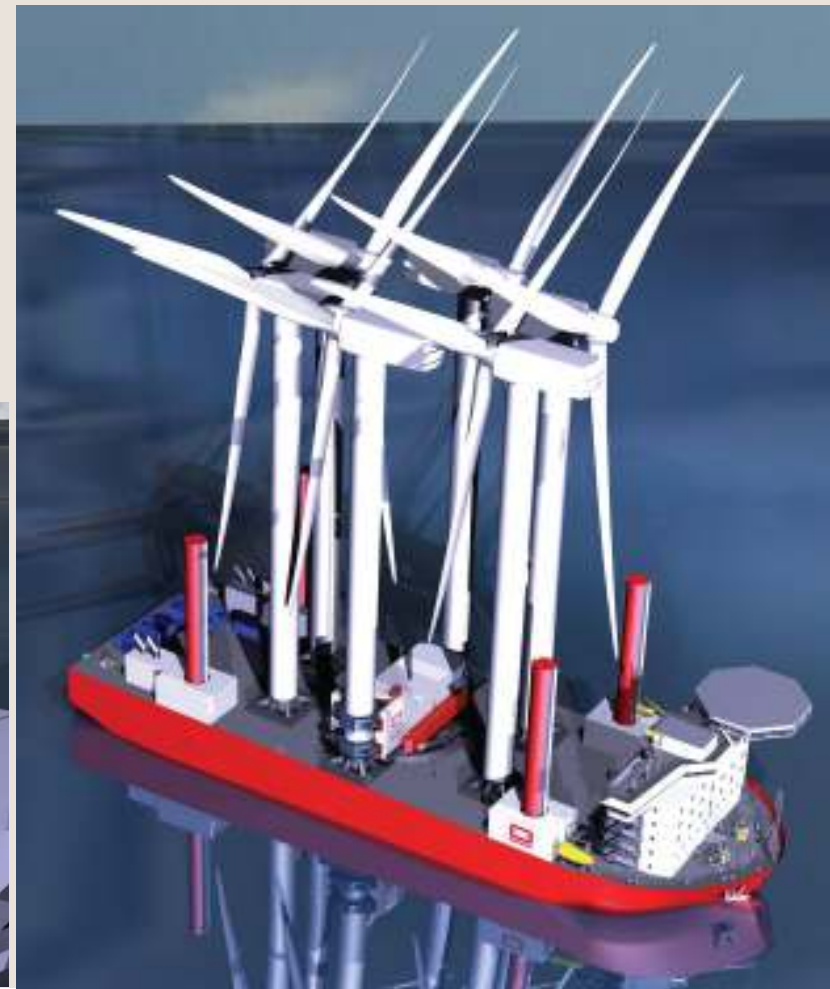

<Concept>, Jack-up type (1)

Length: 140 m, Weight: 11400 t, Max. water depth: 45 m

Future Developments Offshore

5b Wind-turbine & foundation installation vessels

Integrated design and turnkey delivery



<Concept>, Jack-up type (2)

Length: 200 m, Weight: 14000 t, Max. water depth: 45 m

Future Developments Offshore

5c Wind-turbine & foundation installation vessels

Integrated design and turnkey delivery

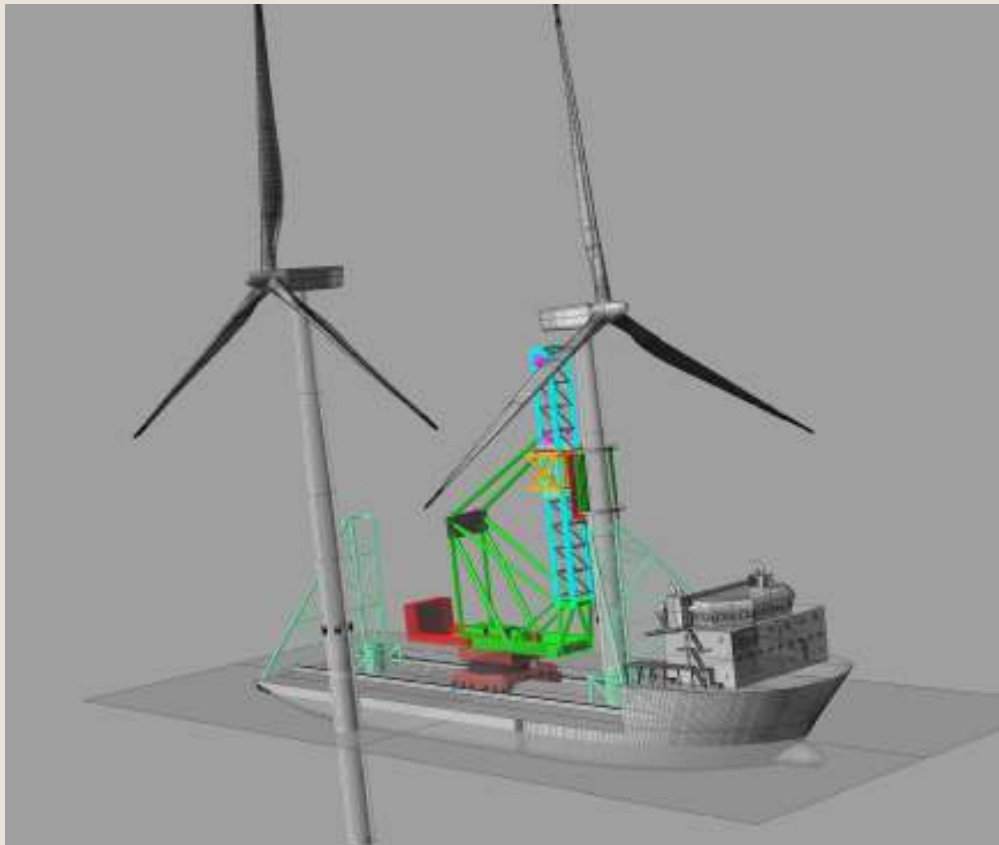

- No jacking procedures
- Fast installation
- High-end hydraulic system & automation
- Superior weather window

<Concept>, Floating type

Length: 160 m, Weight: 12500 t

Future Developments Offshore

6 Integrated modular multi-purpose offshore vessels

Integrated design and turnkey delivery of vessel & modules
Avoids expensive and time consuming rebuilds



<Concept>, Skid-type modular vessel



END

Thanks for your attention

Questions are welcome

G. Hamers

16 juni 2009



The technology innovator.